

PRESSURE DROP (at 6 bar)

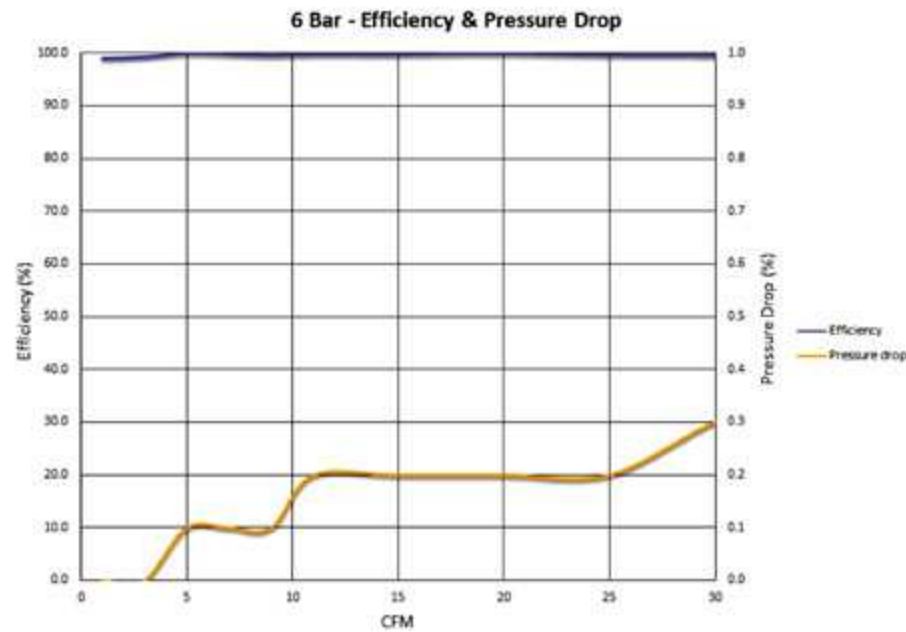

PRESSURE DROP (at 8 bar)

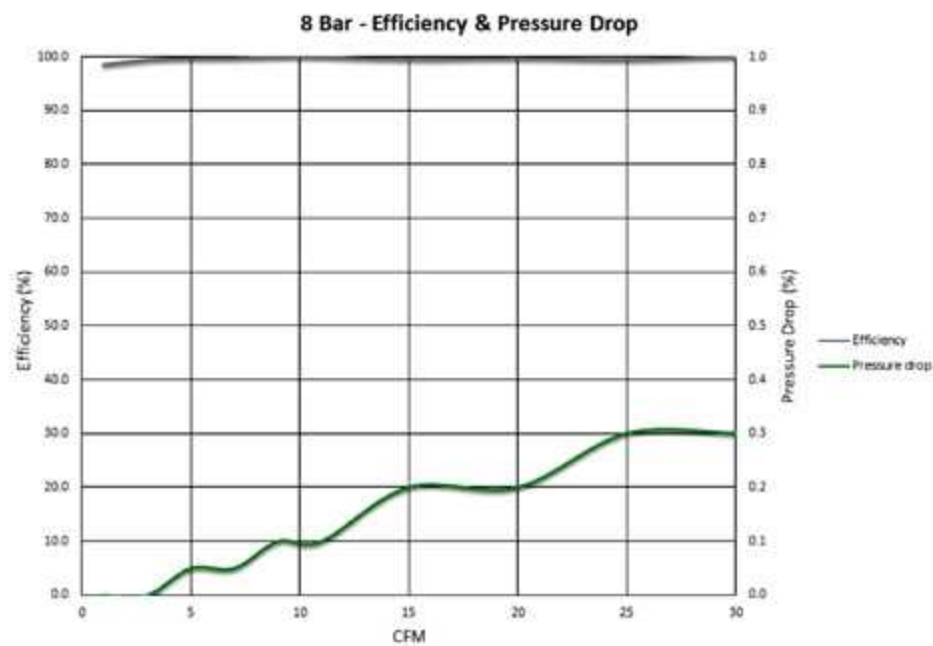

EXPEL 30 - POINT OF USE LIQUID WATER, OIL & PARTICULATE COMPRESSED AIR FILTER

Exceptional compressed air quality guaranteed

Expel will dramatically improve compressed air systems throughout the industry. The unique patented design allows it to efficiently remove 99.9999% of liquid, oil, water and removes other contaminants down to 1 micron when installed at point of use.

Expel 30

PRODUCT OVERVIEW

- 30 cfm max rated flow rate
*See technical data on pages 2, 3 & 4
- 15 bar(g) - 217 psi(g) maximum pressure
- 5 year manufacturer's warranty
- ½" & ¾" BSPT / NPT inlet / outlet connections
- Removes 99.9999% all liquid water, oils, and filters particulates down to 1 micron
- Grade 304 stainless steel body and head
- Pressure indicator as standard
- Optional pressure gauge.
- ½" BSPT / NPT male drain port

FEATURES

- Tested to ISO 12500 - part 3 & 4 standard
- World's first cleanable, reusable compressed air filter
- No increase in pressure drop caused by contaminated filters
- No power source required
- Significantly reduced life cycle costs
- Easy to install & maintain
- Instantaneous recovery from pulsed flows or stop start
- All spare parts available
- Fully dismantlable
- No decrease in performance over lifetime of well maintained filter



TECHNICAL DATA

OPERATIONAL SPECIFICATION

	0.14 - 0.85m ³ /min
Flow rate for a 7 bar(g) system	8.5 - 51 m ³ /hr 5 - 30 cfm 141 - 850 litres/min
Operating pressure	1 - 15 bar(g) 15 - 217 psi(g)
Operating temperature	>0 to +80 °C >32 to 176 °F
Maximum recommended inlet temperature	35 °C 95 °F

PRODUCT LINE DRAWING*

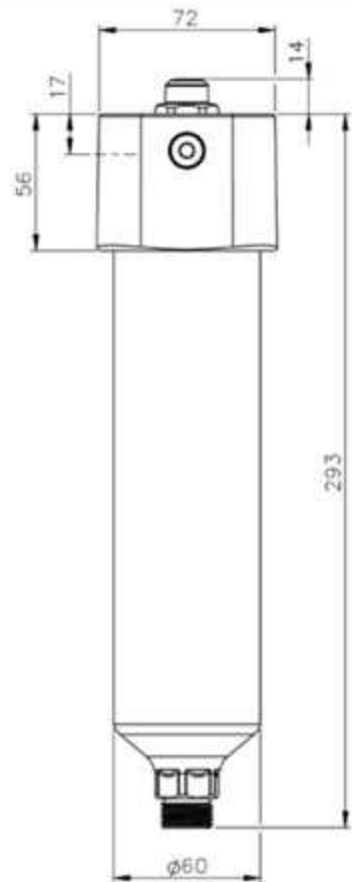

MECHANICAL SPECIFICATION

Product code - 1/2"	6000-002-AA
Product code - 3/4"	6000-003-AA
Inlet/Outlet connection	1/2" or 3/4" BSPT/NPT
Drain connection	1/2" (m) BSPT/NPT
Weight	2.08 kg
Product dimensions	293 mm x 80 mm
Particulate removal	> 1 micron
Material (housing)	Stainless Steel 304
Material (internal)	ABS

LINE DRAWING FOR MOUNTING*

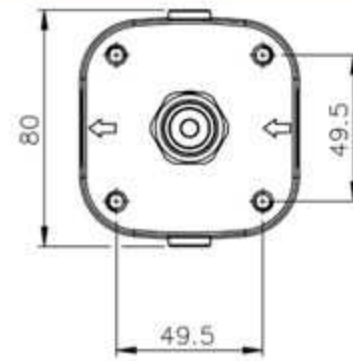

BOX CONTENTS QTY

Expel 30 Unit	1
Mounting bracket	1
Bolts M6 x 8 mm	4
Fixing Screws	4
Wall Plugs	4
Manual	1

Manual and Automatic drains available contact us or visit our website www.nexflow.com

*Not to scale

PRESSURE DROP (at 7 bar)

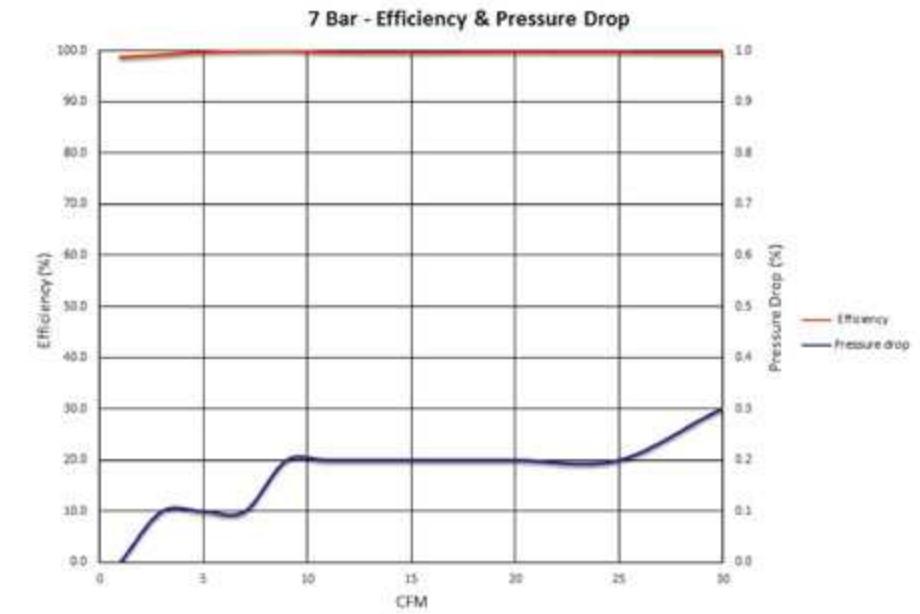

LIQUID WATER REMOVAL

