

Dimension Table of TBI MOTION Ball Screws

Used for Milling Machine Only

TYPE : SFM

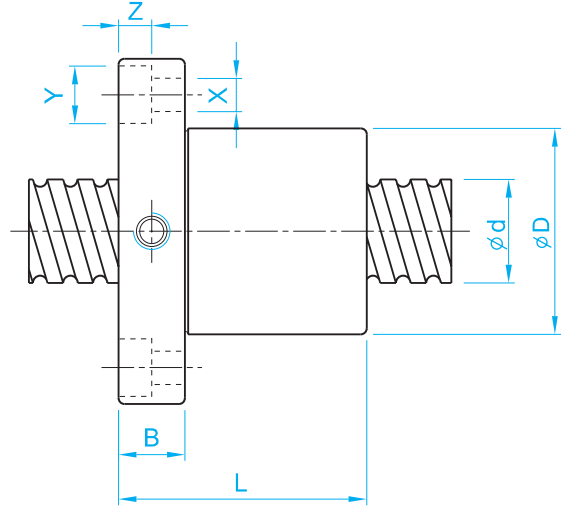

TYPE : DFM

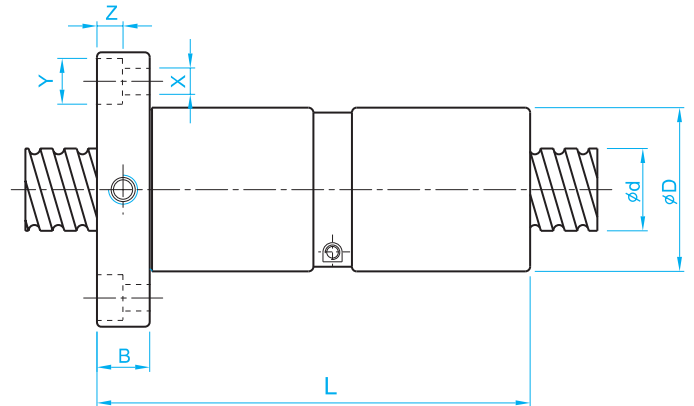

Unit : mm

I: Lead Da: Ball Dia. n: Number of Circuits K: Stiffness (Kgf/μm)
 Ca: Basic Dynamic Rating Load (Kgf) Coa: Basic Static Rating Load(Kgf)

| Model No. | Dimensions | | | | | | | | | | | | | | | | |
|--------------|------------|------|-------|----|----|----|-----|----|----|-----|----|-----|----|-----|------|------|----|
| | d | I | Da | D | A | B | L | W | H | X | Y | Z | Q | n | Ca | Coa | K |
| ★ SFM03205-4 | 32 | 5 | 3.175 | 48 | 74 | 12 | 52 | 60 | 60 | 6.5 | 11 | 6.5 | M8 | 1x4 | 1922 | 6343 | 53 |
| ★ SFM0325T-4 | | 5.08 | 3.175 | 48 | 74 | 12 | 53 | 60 | 60 | 6.5 | 11 | 6.5 | M8 | 1x4 | 1922 | 6343 | 53 |
| ★ DFM03205-4 | 32 | 5 | 3.175 | 48 | 74 | 12 | 102 | 60 | 60 | 6.5 | 11 | 6.5 | M8 | 1x4 | 1922 | 6343 | 73 |
| ★ DFM0325T-4 | | 5.08 | 3.175 | 48 | 74 | 12 | 104 | 60 | 60 | 6.5 | 11 | 6.5 | M8 | 1x4 | 1922 | 6343 | 73 |

Note: with sign ★ can be produced in left helix