

## Dimension Table of TBI MOTION Ball Screws

(TYPE) SFE

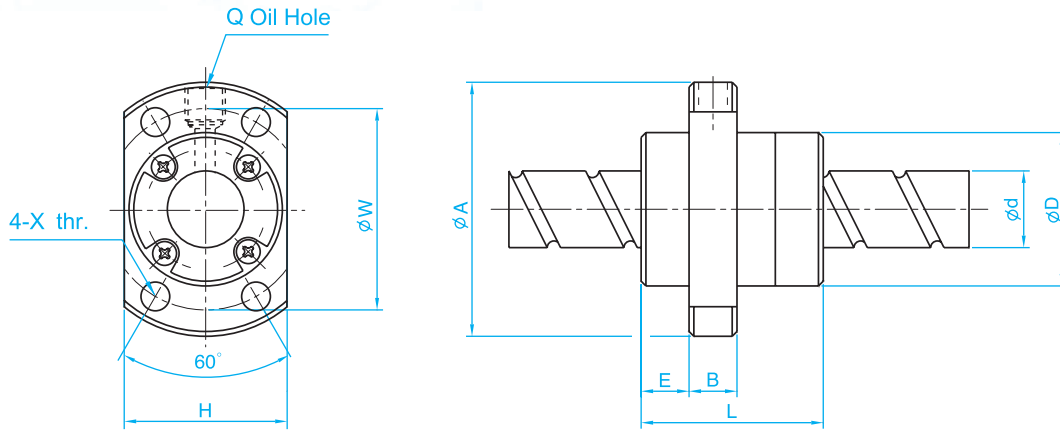

Unit : mm

l: Lead    Da: Ball Dia.    n: Number of Circuits    K: Stiffness (Kgf/μm)  
 Ca: Basic Dynamic Rating Load (Kgf)    Coa: Basic Static Rating Load(Kgf)

Model No.	Dimensions															
	d	l	Da	D	A	E	B	L	X	W	H	Q	n	Ca	Coa	K
SFE01616-3	16	16	2.778	32	53	10.1	10	38	4.5	42	34	M6	1.7x2	1021	2409	29
SFE01616-6		16	2.778	32	53	10.1	10	38	4.5	42	34	M6	1.7x4	1853	4818	57
SFE01632-3	16	32	3.175	34	55	10.5	10	34	5.5	45	36	M6	0.7x2	518	1094	11
SFE01632-6		32	3.175	34	55	10.5	10	34	5.5	45	36	M6	0.7x4	939	2188	21
SFE02020-3	20	20	3.175	39	62	12	10	47	5.5	50	41	M6	1.7x2	1321	3320	35
SFE02020-6		20	3.175	39	62	12	10	47	5.5	50	41	M6	1.7x4	2397	6640	67
SFE02040-3	20	40	3.175	38	58	11	10	41	5.5	48	40	M6	0.7x2	582	1397	13
SFE02040-6		40	3.175	38	58	11	10	41	5.5	48	40	M6	0.7x4	1056	2794	26
SFE02525-3	25	25	3.969	47	74	14	12	57	6.6	60	49	M6	1.7x2	1974	5188	43
SFE02525-6		25	3.969	47	74	14	12	57	6.6	60	49	M6	1.7x4	3583	10377	83
SFE02550-3	25	50	3.969	46	70	13	12	50	6.6	58	48	M6	0.7x2	870	2183	16
SFE02550-6		50	3.969	46	70	13	12	50	6.6	58	48	M6	0.7x4	1579	4366	32
SFE03232-3	32	32	4.762	58	92	17	12	71	9	74	60	M6	1.7x2	2876	8207	54
SFE03232-6		32	4.762	58	92	17	12	71	9	74	60	M6	1.7x4	5220	16414	106
SFE03264-3	32	64	4.762	58	92	15.5	12	62	9	74	60	M6	0.7x2	1225	3282	20
SFE03264-6		64	4.762	58	92	15.5	12	62	9	74	60	M6	0.7x4	2223	6565	39
SFE04040-3	40	40	6.35	73	114	19.5	15	89	11	93	75	M6	1.7x2	4600	13281	66
SFE04040-6		40	6.35	73	114	19.5	15	89	11	93	75	M6	1.7x4	8348	26561	128
SFE05050-3	50	50	7.938	90	135	21.5	20	107	14	112	92	M6	1.7x2	6512	19430	80
SFE05050-6		50	7.938	90	135	21.5	20	107	14	112	92	M6	1.7x4	11820	38859	155

Note: 1. "-3" means 2 starts, "-6" means 4 starts.

Note: 2. TBI MOTION Standard nuts are without seals, if required, please advise.