

P8o8G

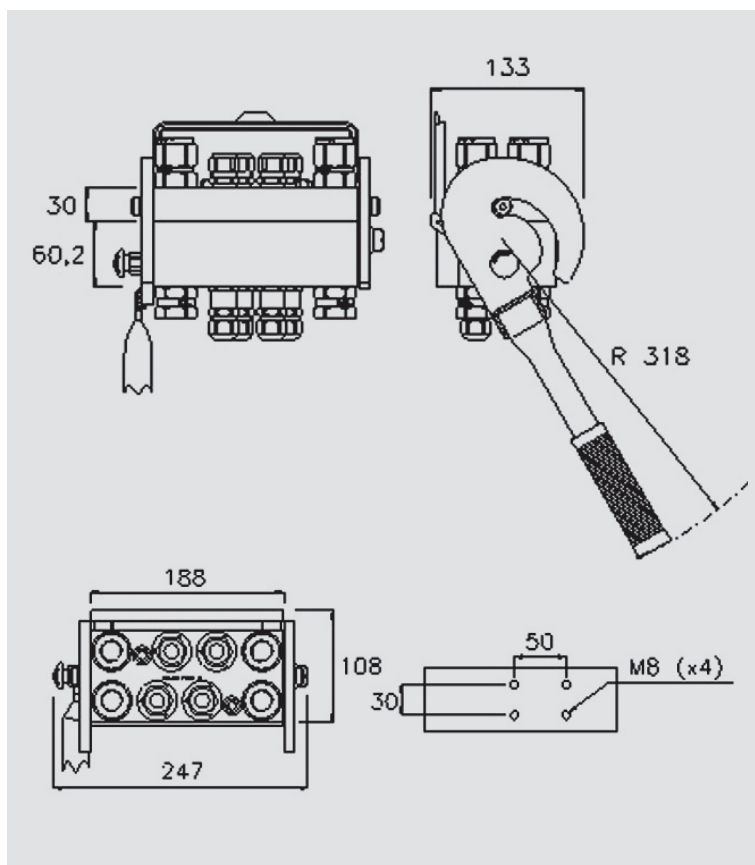

Multifaster 8 lines, size o8, "G" type, with greaser and Zinc-Nickel plating

Applications



Technical Specifications

dash	Size		Working Pressure (MPa)	Flow Rate (l/min)	Spillage (ml)	Burst pressure (MPa)		
	mm	inch				Male	Female	Male + Female
08	12,5	1/2"	25	70	0,01	100	100	100

Material	Aluminium; Steel	Valve Type	Flat
Seals	NBR; PUR	Connection	Lever
Working temperatures	- 25 °C to 100 °C	Disconnection	Lever
Surface treatment	MATE 1000 (ZnNi); Paint	Connection Under Pressure	Allowed Residual

P8o8G

Size					Thread Type					FIXED
dash	mm	inch	Housing	Number of Couplings	Thread Type	Standard	Thread	Electrical Connector N	Connector Type	Part Number
08	12,5	1/2"	8	8	F BSPP	ISO 1179-1	BSPP 1/2" FEMALE			2P808G-8-12G FC

Size					Thread Type					MOBILE
dash	mm	inch	Housing	Number of Couplings	Thread Type	Standard	Thread	Electrical Connector N	Connector Type	Part Number
08	12,5	1/2"	8	8	F BSPP	ISO 1179-1	BSPP 1/2" FEMALE			3P808G-8-12G MC

