

# EK

## Fixed Side

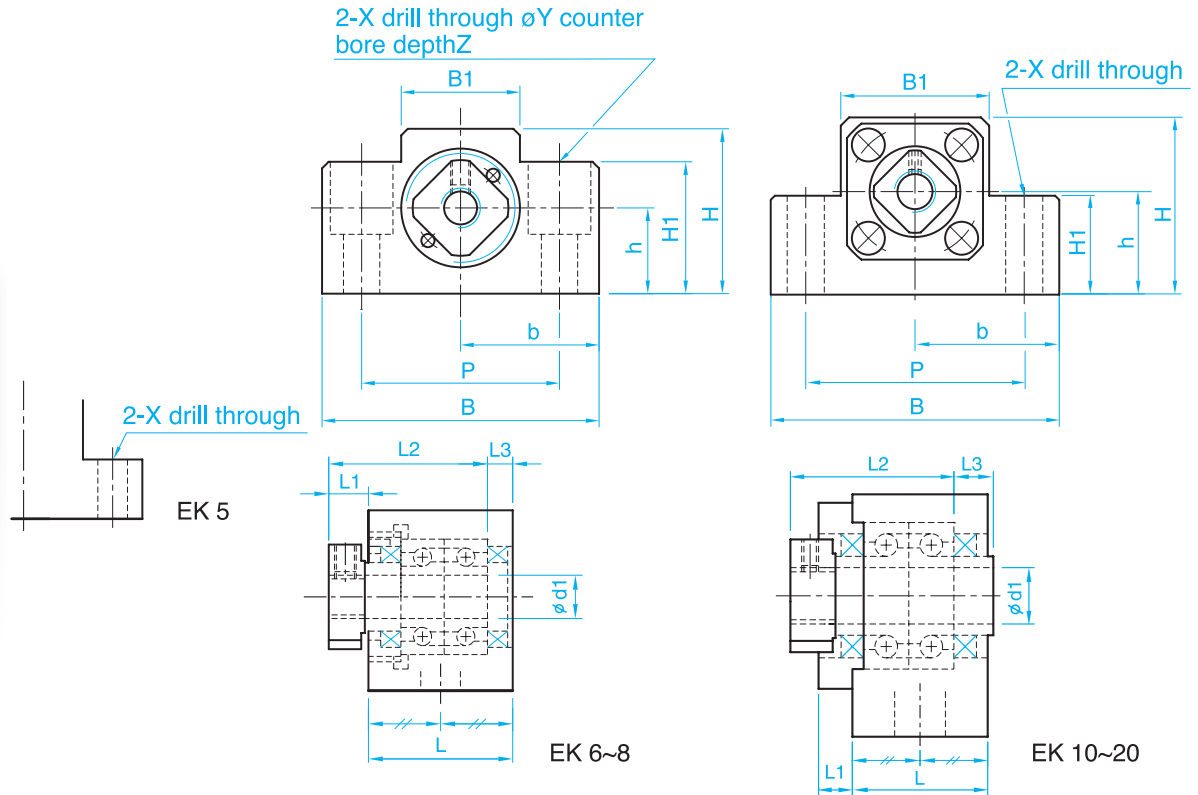
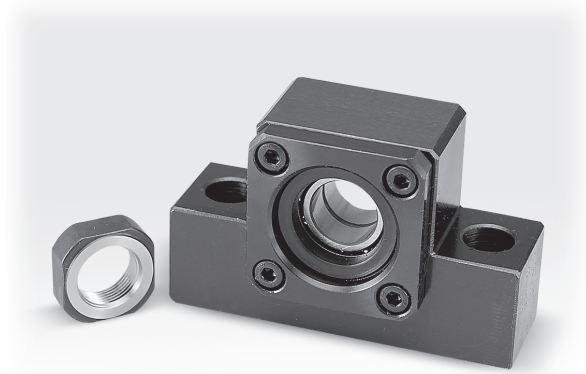

Unit : mm

Model No.	d1	L	L1	L2	L3	B	H	b <sup>+0.02</sup>	h <sup>+0.02</sup>	B1	H1	P	X	Y	Z
EK 5	5	16.5	5.5	18.5	3.5	36	21	18	11	20	8	28	4.5	—	—
EK 6	6	20	5.5	22	3.5	42	25	21	13	18	20	30	5.5	9.5	11
EK 8	8	23	7	26	4	52	32	26	17	25	26	38	6.6	11	12
EK 10	10	24	6	29.5	6	70	43	35	25	36	24	52	9	—	—
EK 12	12	24	6	29.5	6	70	43	35	25	36	24	52	9	—	—
EK 15	15	25	6	36	5	80	49	40	30	41	25	60	11	—	—
EK 20	20	42	10	50	10	95	58	47.5	30	56	25	75	11	—	—