

**Ordering codes**  
 3-wai solenoid valve-LSV2-08-3C-NNN  
 coil LC2-08-C-1H-(12VDC)  
 coil LC2-08-C-2H-(24VDC)

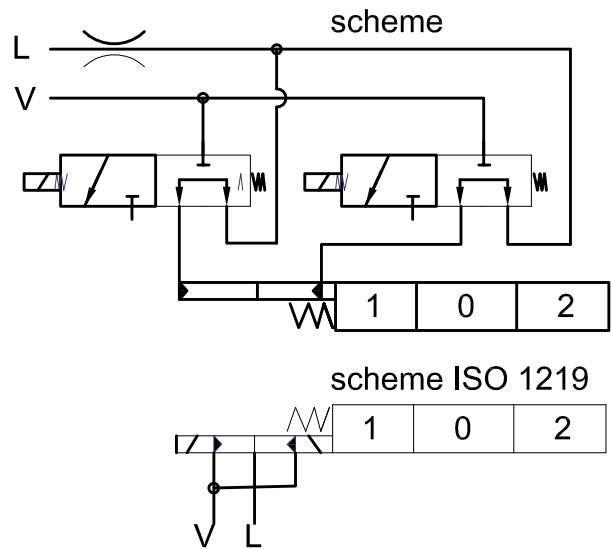

**Operating pressure** min 10 bar(145 psi)  
 max 50 bar(725 psi)  
**Max operating pressure in L (T line)** 25 bar(360 psi)  
**Solenoid operating features**  
**Nominal voltage tolerance** ±10%  
**Power rating** 24W  
**Duty cycle** 100 %

With collector kit for external pilot and drain – CEED...(1,2,3 ...)  
 Коллектор для внешнего питания управления и слив

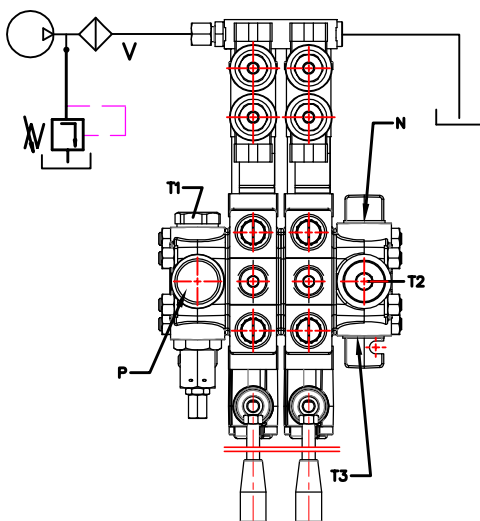

**Ordering example**  
 2PC100/N2/1/PAED3/PAED3 /G/KZ1/T2/CEED2/12VDC

2PC100/N2/1/PAED3/PAED3 /G/KZ1/T2/CEED2/12VDC

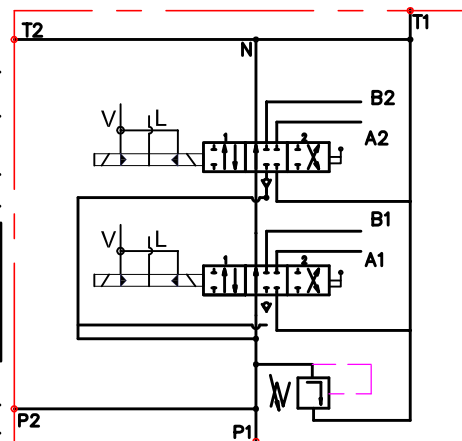

**Ordering codes – collector kits**

- CEED1PC70 Kit for 1 section
- CEED2PC70 Kit for 2 section
- CEED3PC70 Kit for 3 section
- CEED4PC70 Kit for 4 sektion
- .....

ED3 – electro-hydraulic control ON-OFF  
 Электрогидравлический контрол ON-OFF

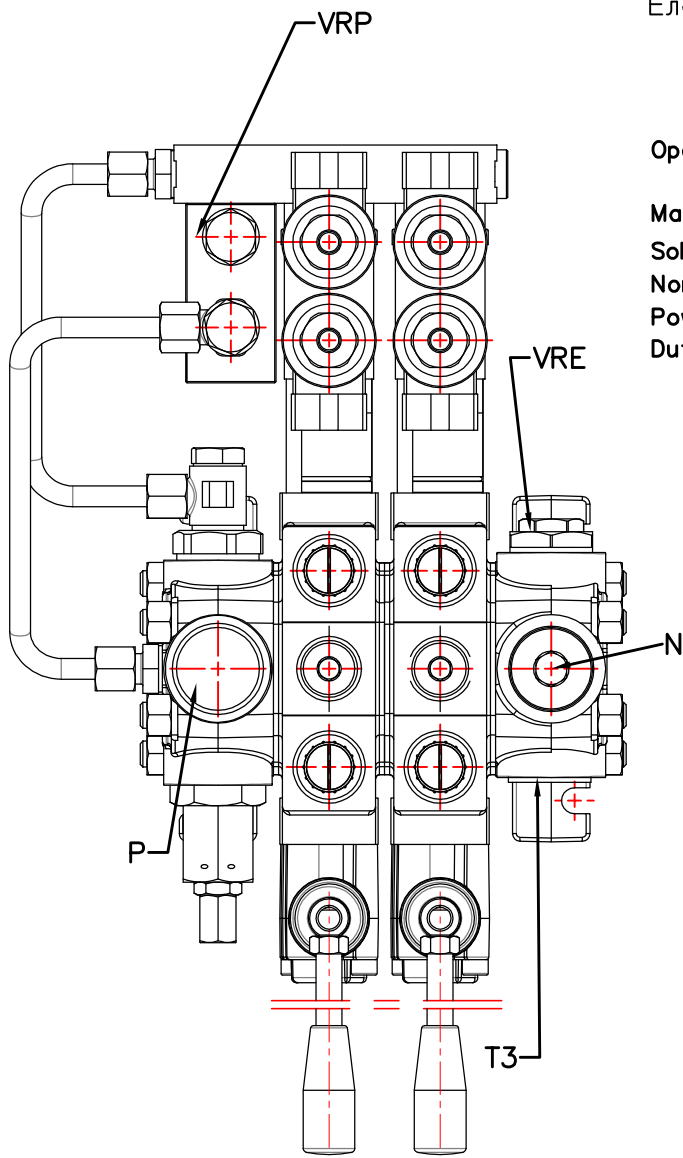

Operating pressure min 10 bar (145 psi)  
 max 50 bar (725 psi)

Max operating pressure in L (T line) 25 bar (360 psi)

Solenoid operating features

Nominal voltage tolerance  $\pm 10\%$

Power rating 24W

Duty cycle 100 %

2PC100/N2/VRP/1/PAED3/PAED3/T3/G/KZ1/CED2/VRE/12VDC

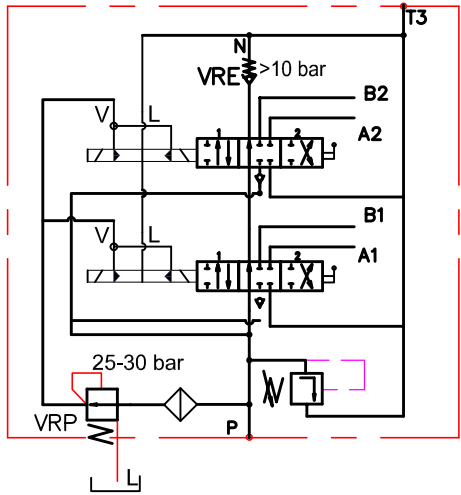

Ordering example

2PC100/N2/VRP/1/PAED3/PAED3/T3/G/KZ1/CED2/VRE/12VDC

Colector kit - Ordering codes  
 BSP threads  
 CED1PC70 Kit for 1 section  
 CED2PC70 Kit for 2 section  
 CED3PC70 Kit for 3 section  
 CED4PC70 Kit for 4 sektion  
 . . . . .

Back pressure valve VRE-PC70  
 Клапан подпорный на слив

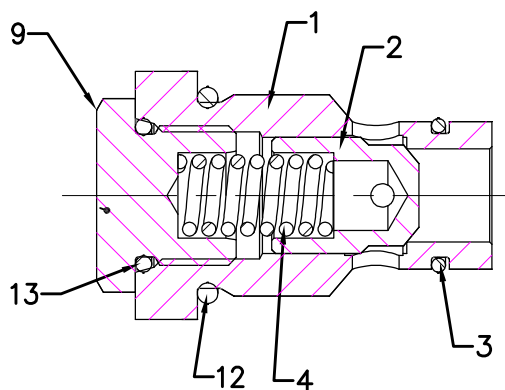

Pressure drop N-T

