

D68 A1 GKZ1

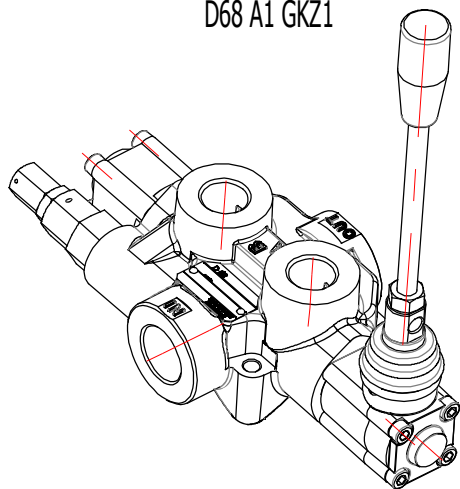

D68R A1 GKZ1

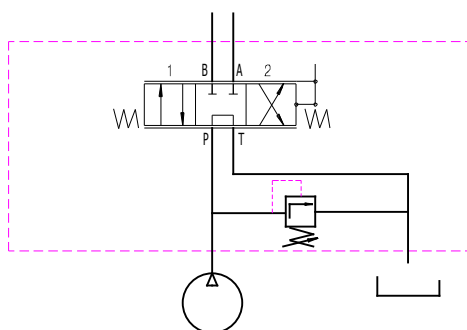
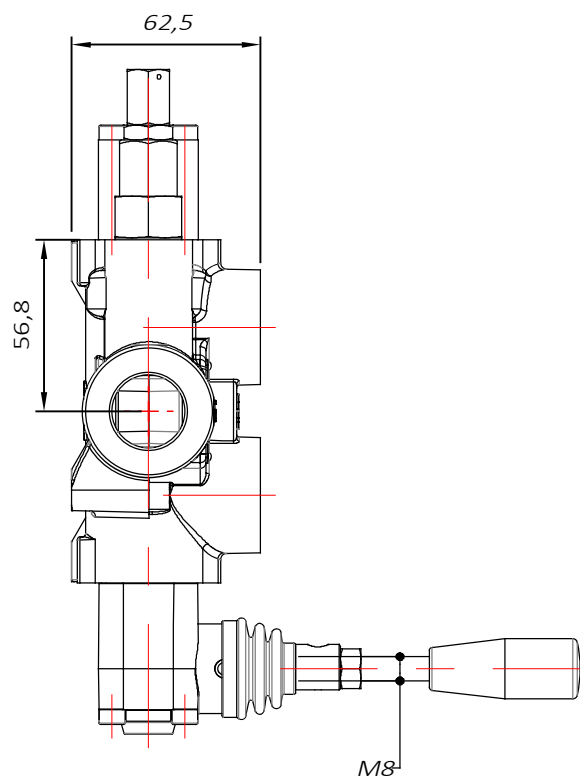
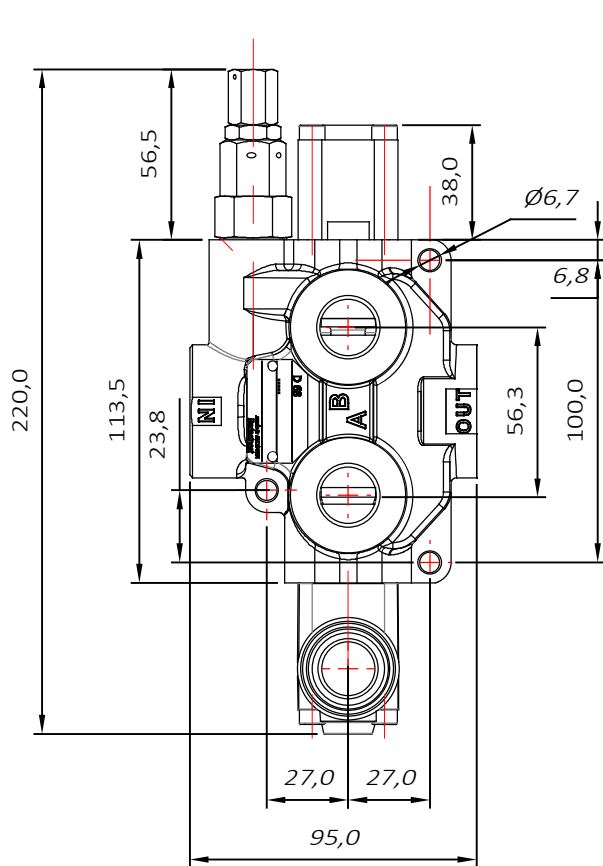
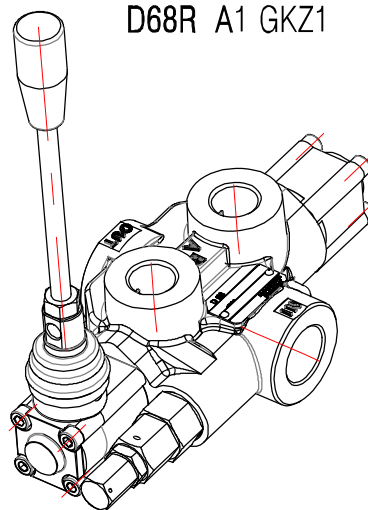

SPECIFICATIONS:

Q - rated for 0-68 l/min - (0 - 20 gpm)
 P - rated for 207 bar - (3000 psi)
 Weight: 2.5 kg - (5 1/2 lbs.)
 Std. Port sizes:
 G 3/4 Inlet/outlet and G 1/2 work ports
 # 12SAE Inlet/outlet and #10 work ports
 25 Micron filtration recommended.

MATERIALS:

Cast Iron Body
 NBR O Rings
 Hard Chromium plated spools

2. SPOOL TYPE

The spool types offered are tandem center 4 way (A), open center 4 way (D)(motor), tandem 3 way (B), tandem metering (Af), closed center 4 way (M).

The spool M requires a pressure compensated pump.

3. ACTUATORS

Standard enclosed lever handle -(KZ), with lever (KZ1), no actuator (-), R- rotary handle used to rotate spool in or out of the valve body.

4. SPOOL CONTROL

Friction detent (0) applies friction to the spool so that the spool does not move when the handle is released either side of neutral, a detent groove clearly indicates neutral position.

Spring center (1) returns the handle to neutral when the handle is released.

Spring center detent (3) springs back to neutral from one position and is mechanically detented in the other position (flow out port A in detent-pos. 2).

Three positions detent (8) hold the spool in neutral and work in both active positions.

E - open electric switch type Omron V 165 used with 0, 1 and 8 spool controls.

T - (teton) used with 2 and 6 spool controls.

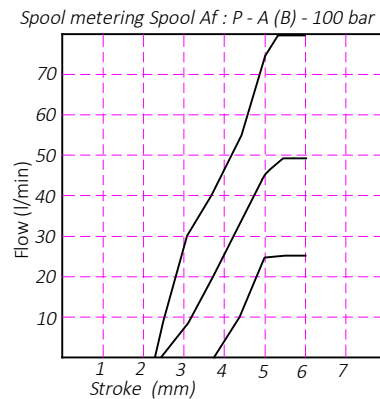
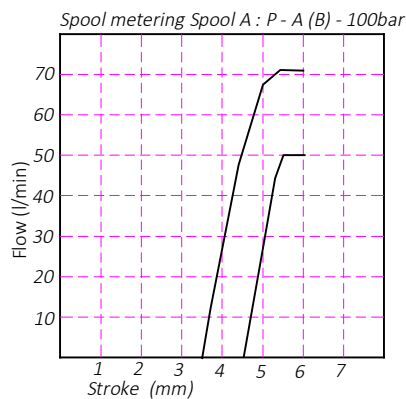
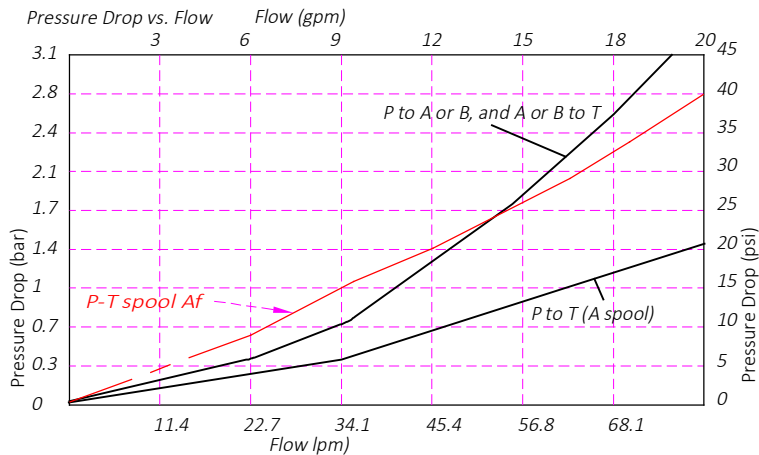
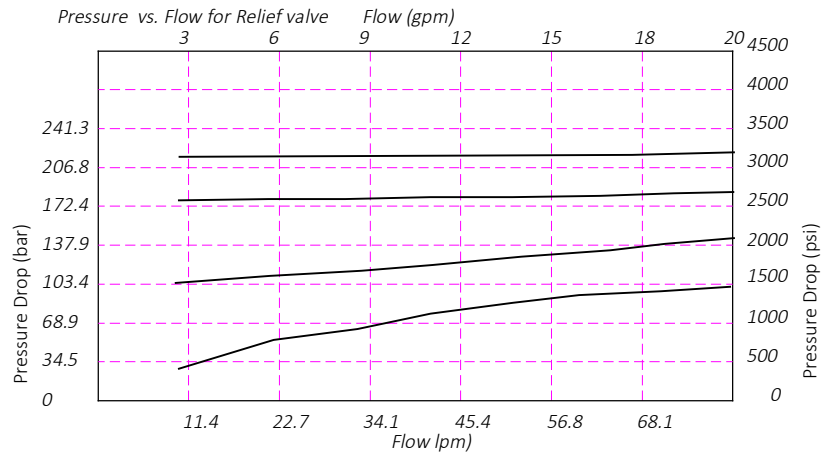

D 68/ . / . / OK/ A/ 1/ G/ KZ 1/ T/ E

-- left inlet
R -- right inlet

"-" -- with RV
"svp" -- with blanking plug

"OK" -- with check valve

"-" -- without check valve

Spool type -- Table 1

Spool positioner -- Table 2

Thread specification -- Table 3

Manual control options -- Table 4

Presence of lever for enclosed lever systems

Presence of control pin for enclosed lever systems

Presence of microswitch

Other

Lever for enclosed handle - 1

Presence of control pin
for enclosed lever system - T
with spool control 3 and 6

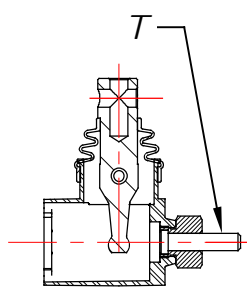

Microswitch - E
normal open

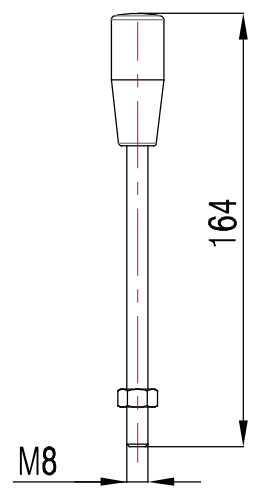
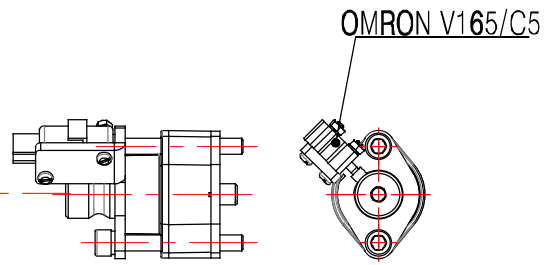

Code Badestnost		Scheme spools
A		
Af		
B		
C		
D		
M		

Table 3

standard

Code	P, T	A, B
G DIN 3852-2	G3/4"	G1/2"
SAE SAE J1926-1 (ISO 11926-1)	SAE12	SAE10
NPT ANSI-ASME B1.20.1	3/4"NPT	1/2"NPT

code	spool control				
0		<table border="1"><tr><td>1</td><td>0</td><td>2</td></tr></table>	1	0	2
1	0	2			
1		<table border="1"><tr><td>1</td><td>0</td><td>2</td></tr></table>	1	0	2
1	0	2			
2		<table border="1"><tr><td>1</td><td>0</td><td>2</td></tr></table>	1	0	2
1	0	2			
3		<table border="1"><tr><td>1</td><td>0</td><td>2</td></tr></table>	1	0	2
1	0	2			
4		<table border="1"><tr><td>0</td><td>2</td></tr></table>	0	2	
0	2				
5		<table border="1"><tr><td>1</td><td>0</td></tr></table>	1	0	
1	0				
6		<table border="1"><tr><td>1</td><td></td><td>2</td></tr></table>	1		2
1		2			
7		<table border="1"><tr><td>1</td><td></td><td>2</td></tr></table>	1		2
1		2			
8		<table border="1"><tr><td>1</td><td>0</td><td>2</td></tr></table>	1	0	2
1	0	2			
9		<table border="1"><tr><td>1</td><td>0</td></tr></table>	1	0	
1	0				
10		<table border="1"><tr><td>0</td><td>2</td></tr></table>	0	2	
0	2				
11		<table border="1"><tr><td>1</td><td></td><td>2</td></tr></table>	1		2
1		2			

Table 4

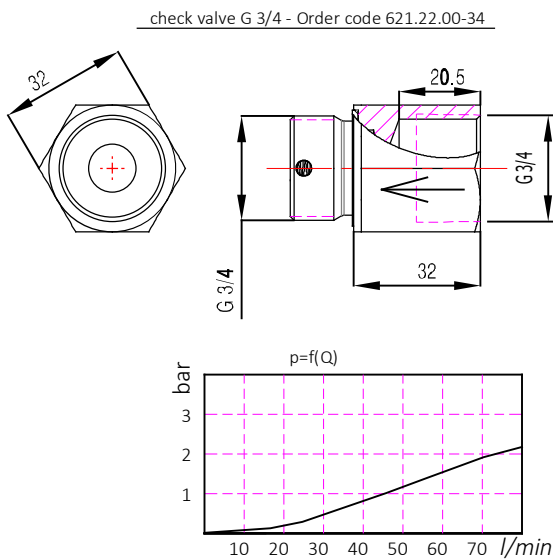

kind of hand control

code	feature	code	feature
KZ		KZ1	
KZ0		KZ01	
-	without hand control ;	-	without hand control ;
R	rotary hand control ;		