

3ZC70/N2/SAES3/TAES3/PAES3/T2/M2

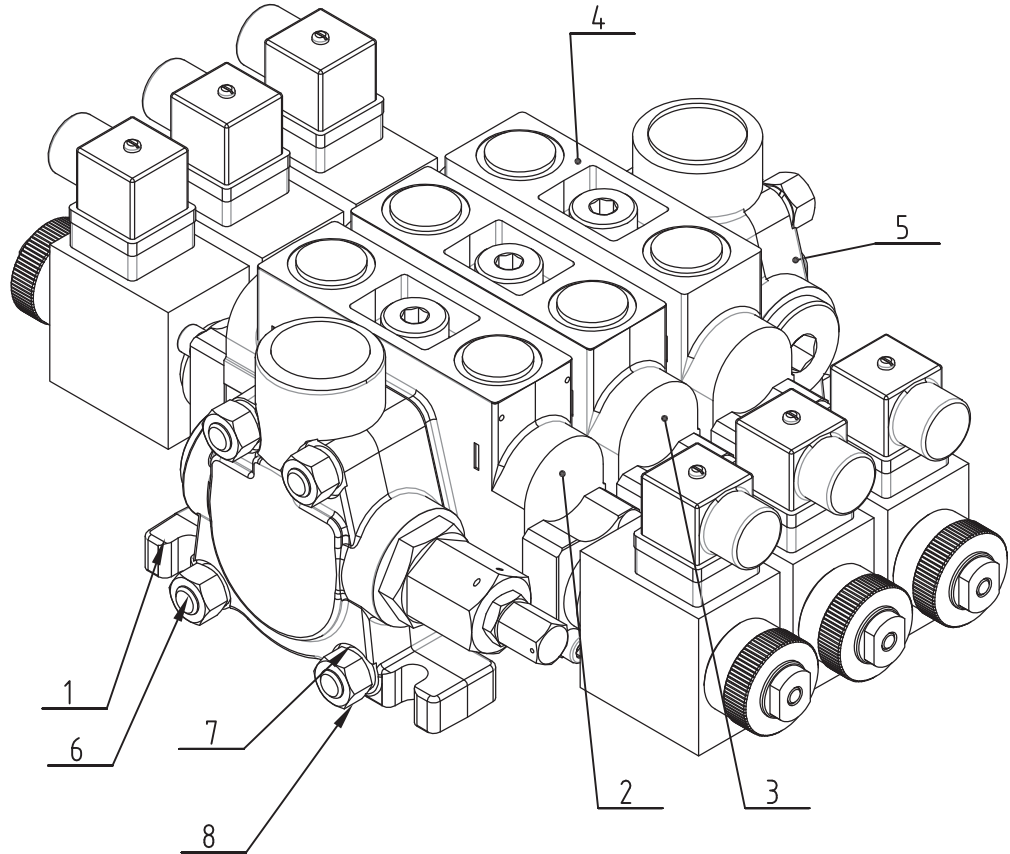

ITEM NO.	PartNo	DESCRIPTION	QTY.
1	293.00.00.00	subplate with pr. relief valve	1
2	564.02.00.00-02	dir. control valve-series-SAES3	1
3	563.02.00.00-02	dir. control valve-tandem-TAES3	1
4	562.02.00.00-04	dir. control valve-parallel-PAES3	1
5	291.00.00.00	endplate	1
6	200.00.00.01-02	tie bolts M10	4
7		spring washer M10	8
8		nut M10	8

weight = 16.079 kg.

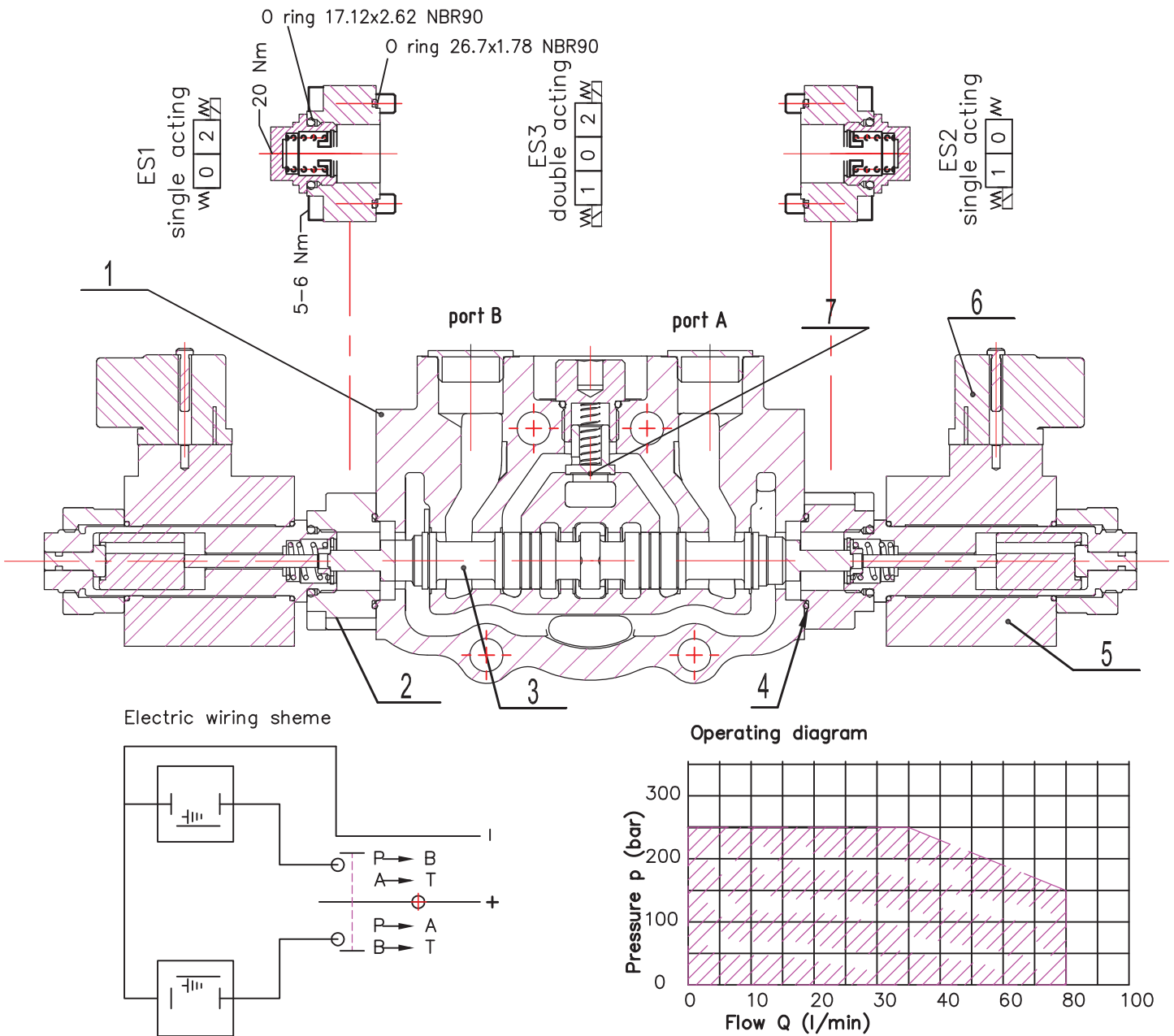

Operating features

Технические примечания

Control

Internal leakage A(B) → T
 (p=120 bar, Viscosity=32, mm²/s : 20 - 40 μcm/min)
 Fluid temperature - -20 C(short time) ... 80 C
 Max. back pressure on outlet port T - 25 bar (360psi)

Coil

Nominal voltage tolerance ±10%
 Power rating 60 W
 Coil insulation class H
 Duty cicle 100%
 Connector ISO 4400
 Emergency manual override

pos.	Part.No	Description	Quantity
7		Check valve	1
6	DIN 43650	connector Pg11	2
5	558.02.04.00	magnet	2
4	O ring 26.7x1.78 NBR90		2
3	562.02.01.00-...	Spool ...ES	2
2	511.02.02.00	Intermediate unit	1
1	562.00.00.01...	Body ...	1

ES ... SOLENOID DIRECT CONTROL

ORDERING EXAMPLE
 Section ZC70 PAES3 12VDC G



Solenoid direct control valve with spring return to neutral position.

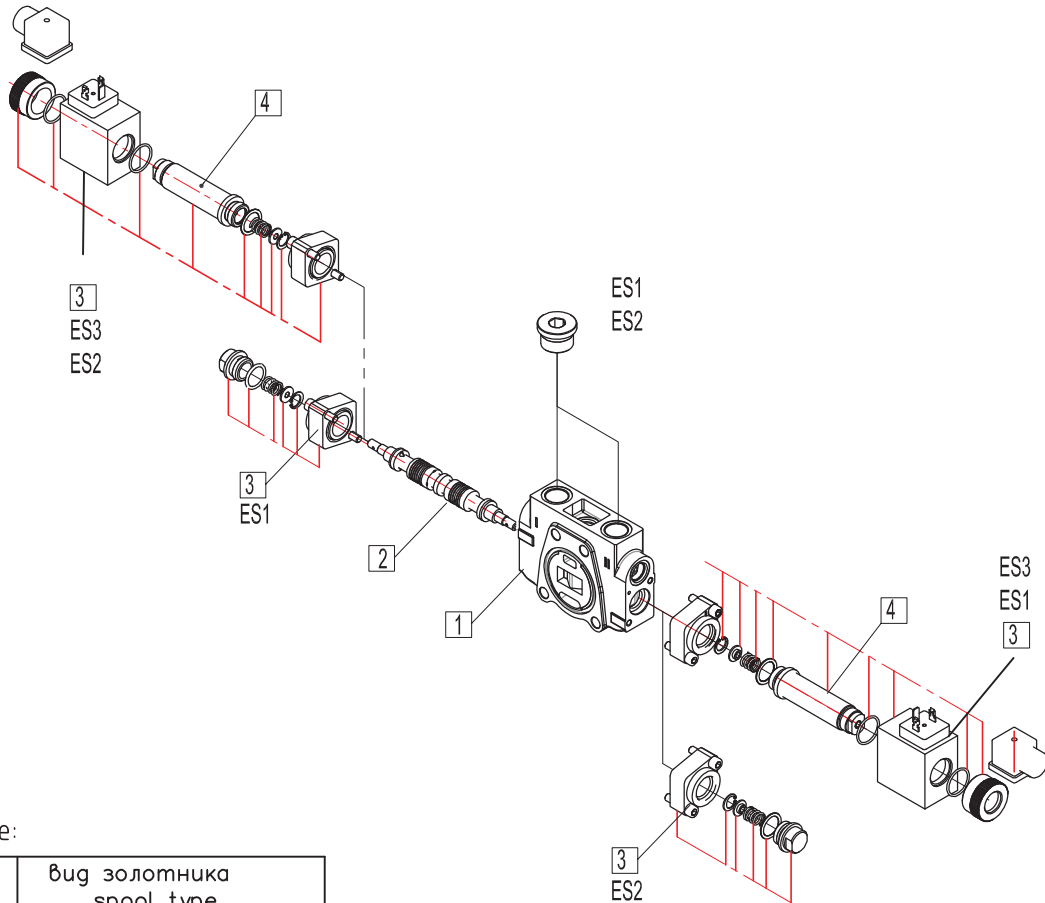

Example:

code	тип золотника spool type
PAES3	
EUL	

1.Body kit

Type	Description
562.00.00.01 parallel	1 spool
563.00.00.01 tandem	1 spool
564.00.00.01 series	1 spool

2.Spool options

Type	Description
A	Double acting, 3 positions with A and B closed in neutral position
D	Double acting, 3 positions with A and B open to Tank in neutral position
B	Single acting, 3 positions with A closed in neutral position
C	Single acting, 3 positions with B closed in neutral position
EUL	electric control unloader spool

3.Control kit

Type	Description
ES1	Single acting P – A with spring return in neutral position
ES2	Single acting P – B with spring return in neutral position
ES3	Double acting P – A, B with spring return in neutral position

4.Coils

Type	Description
(with connector ISO 4400)	
12VDC	Nominal voltage 12VDC
24VDC	Nominal voltage 24VDC

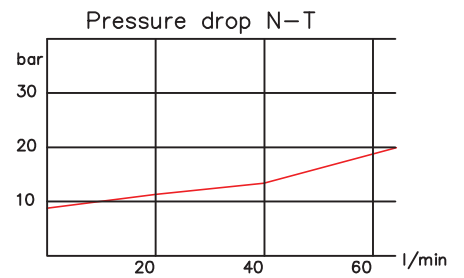
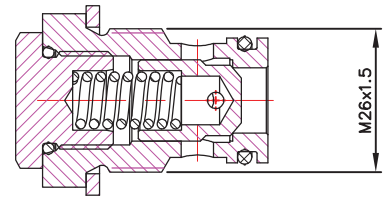
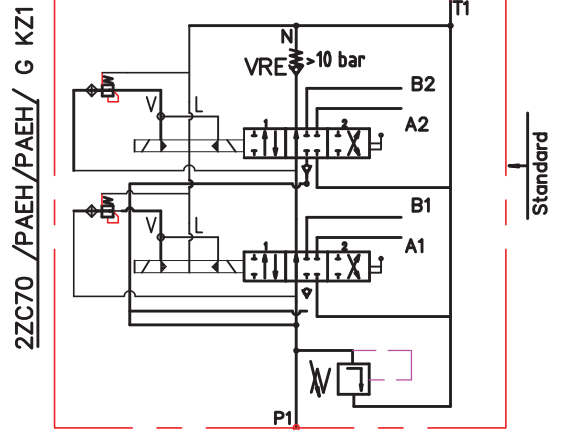
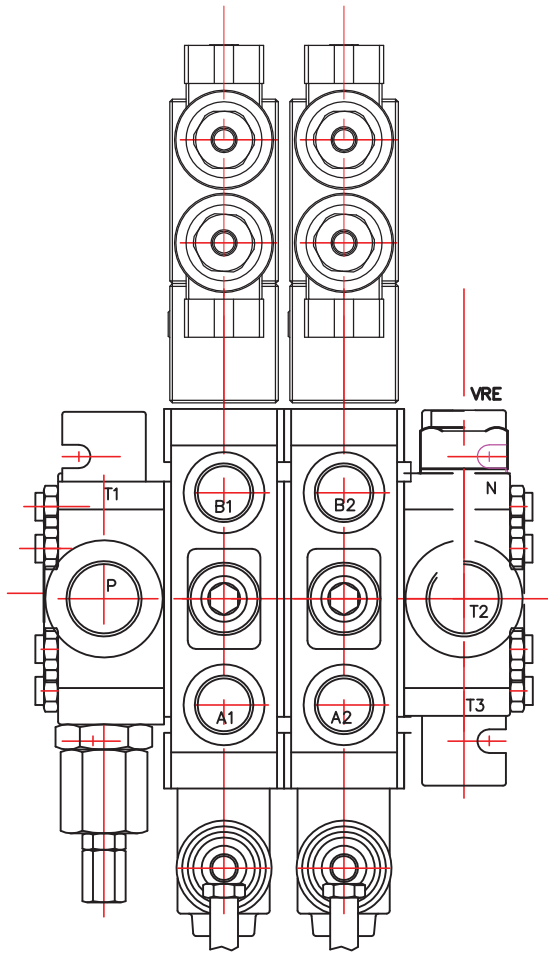

EH- electro-hydraulic control ON-OFF
 Электрогидравлический контрол ON-OFF
 scheme

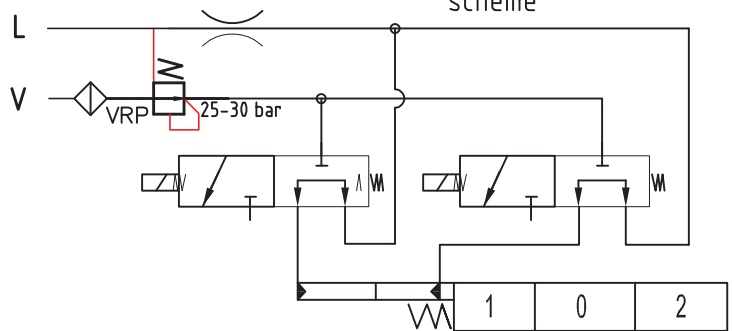

scheme ISO 1219

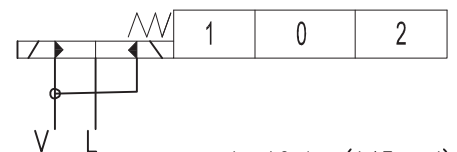

Operating pressure
 min 10 bar(145 psi)
 max 50 bar(725 psi)

Max operating pressure in L (T line)
 25 bar(360 psi)

Solenoid operating features
 Nominal voltage tolerance ±10%
 Power rating 24W
 Duty cycle 100 %

Ordering codes

3-way solenoid valve-LCV2-08-3C-NNN
 coil LC2-08-C-1H-(12VDC)
 coil LC2-08-C-2H-(24VDC)

Распределитель гидравлический ZC 70
 Directional control valve ZC 70

FEATURES

Directional control valve ZC70 is a variant of directional control valve PC70—special body and new spools. In this variant the situation of the spools towards the body is positioned much more precisely and due to this the valve has better throughput. This implies more precise metering diagram too.

The hydraulic valve ZC70 can be implemented with direct control by solenoids ON—OFF (see ZC70 – ES ... solenoid direct control) and series section

Metering curve section PA1, TA1
 Flow characteristics / spool travel

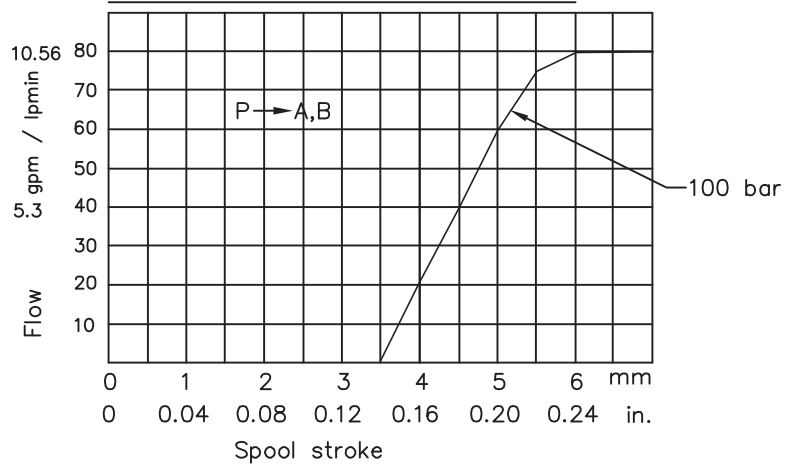

pressure drops section SA1

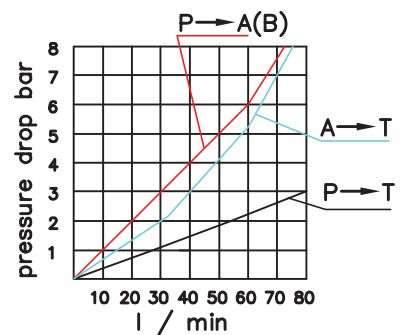
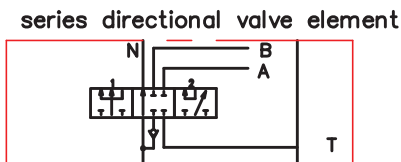

Распределитель гидравлический ZC 70
 Directional control valve ZC 70
 Mid inlet PC70IM...

Scheme with
 PC70IM.S_ – Split Flow Mid-Inlet

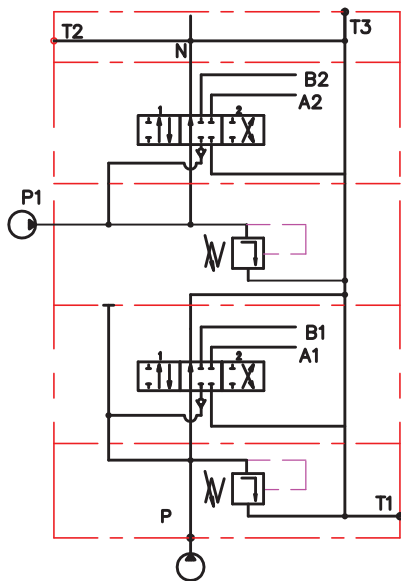

Scheme with
 PC70IM.C_ – Combined Flow Mid-Inlet

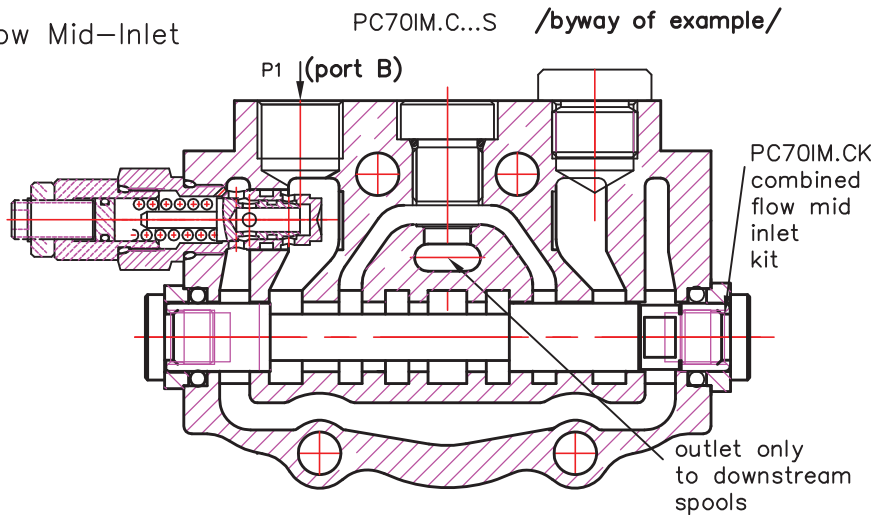
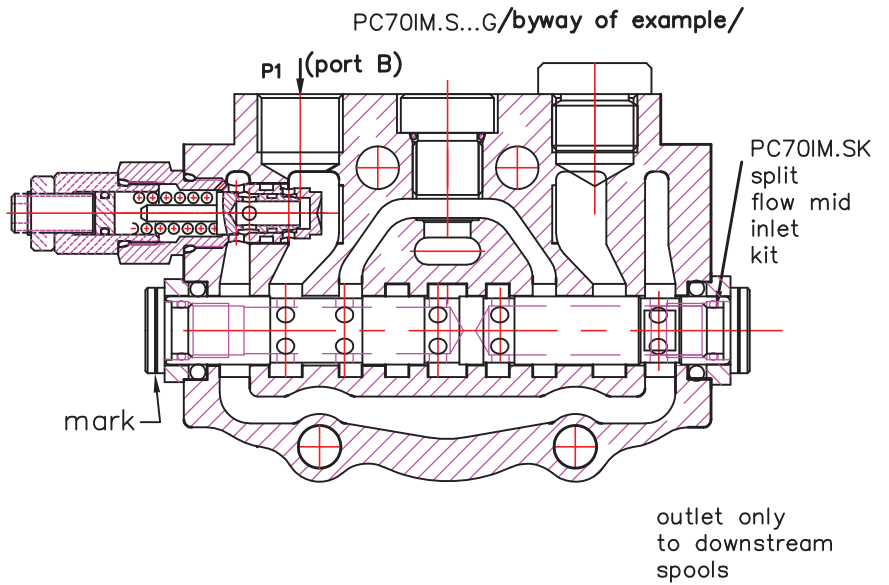
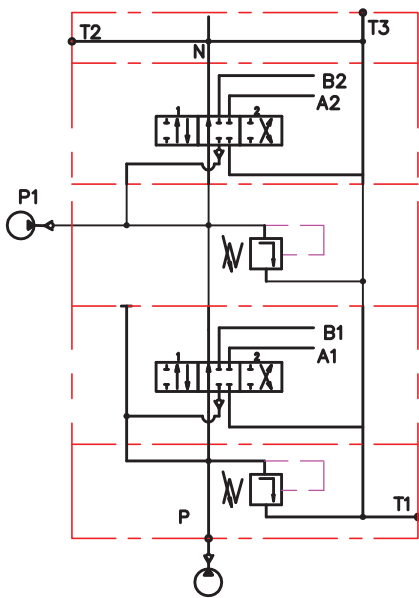

Description

A Mid-Inlet provides an inlet port for a second pump mid stream in the valve stack. A relief valve can be provided in this section.

The split flow inlet completely separates the two pump flows. The common tank passage is shared between the two pump flows.

With the combined flow inlet the flow from both pumps is available to the downstream section when all the work sections upstream are in neutral.

PC70IM.XXX

- G – Port size G1/2
- S – Port size #10 (7/8–14UNF)
- (svp) – No relief valve
- Blank – Adjustable relief valve 50–250 bar (setting 180 at 35 l/min)
- Out of standard relief pressure – text
- S – Split flow mid-inlet
- C – Combined flow mid-inlet

* Section appearances are of parallel section – special body..

Распределитель гидравлический ZC 70
 DF – pressure compensated flow divider section

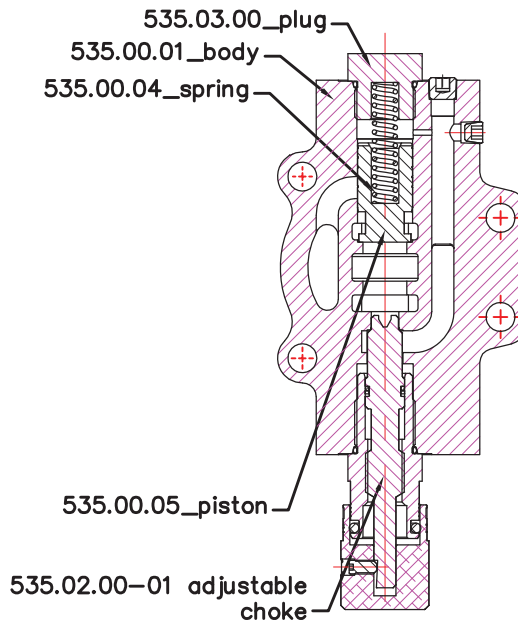
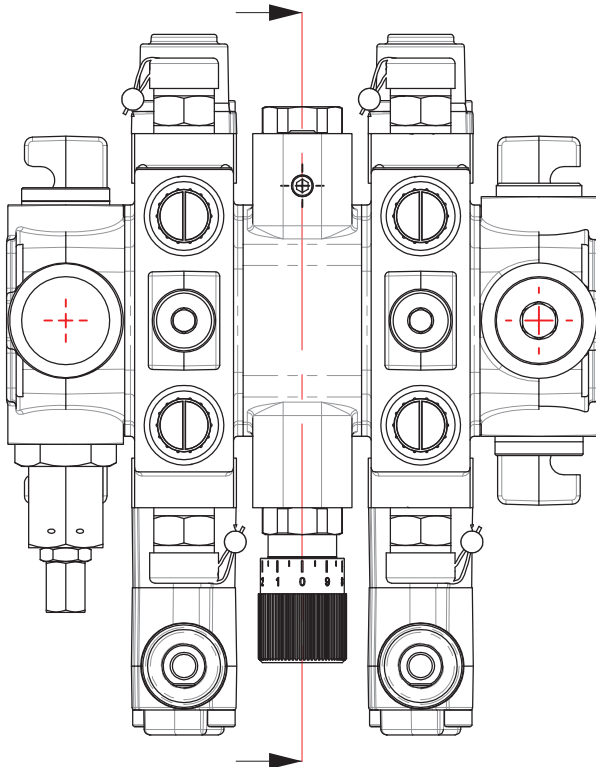

2PC70/N2/PD1/DF/PA1/T2/G/KZ1

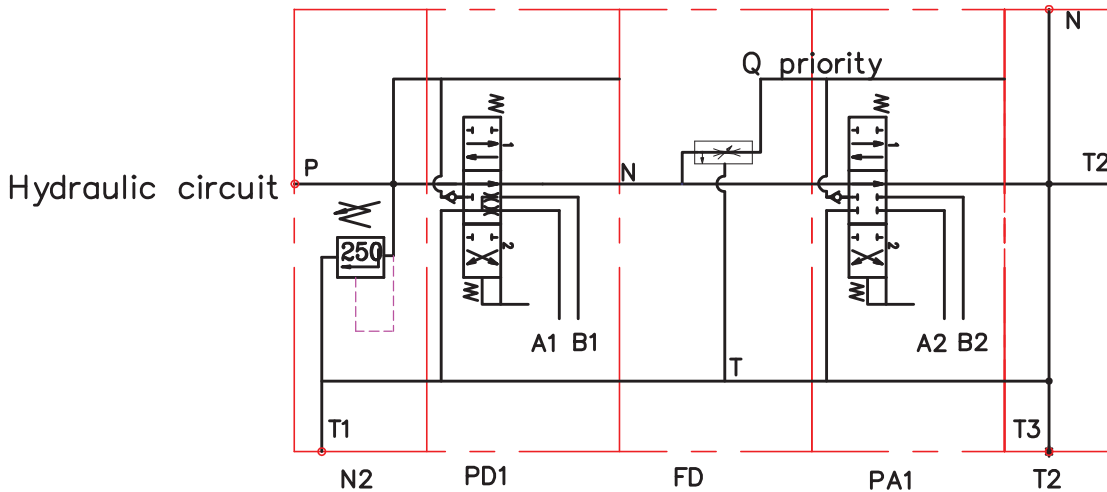

The flow on the downstream sections can be adjusted from 0 to 70 l/min by means of graduated handwheel. Residual flow goes to tank.

Flow regulation diagram
 $Q_n = 80 \text{ l/min}$; $P = 100 \text{ bar}$

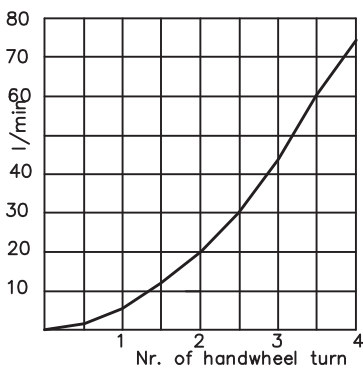

Pressure-flow diagram
 $Q_n = 80 \text{ l/min}$

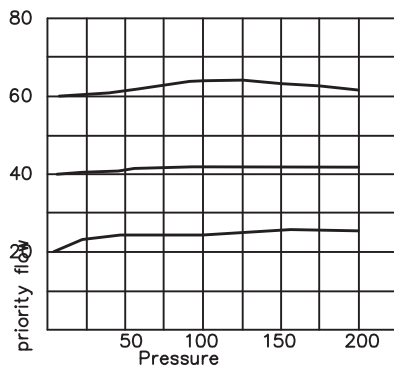

Pressure drop
 $P_{in} - P_{out}$

