

# Series AM

## Air Cylinder/Double Acting

Lube · Non-Lube · Air-Hydro Type(mm)/φ40, φ50, φ63, φ80, φ100



- BUILT-IN AIR CUSHION
- DESIGNED FOR LONG LIFE & HIGH SPEED
- AVAILABLE FOR THE WIDE STROKE & BORE SIZE

Symbol

Double acting

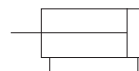

### How To Order

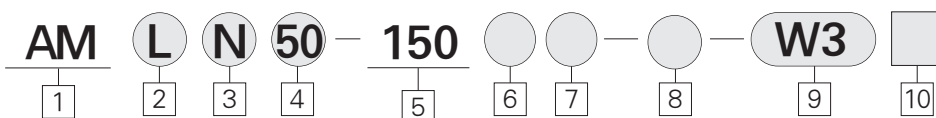

**1 Air Cylinder**  
Standard  
(Built-in magnet)

**2 Mounting**  
B : Standard  
L : Foot  
F : Front flange  
G : Rear flange  
C : Single clevis  
D : Double clevis  
T : Center trunnion

**3 Type**  
Blank : Lubricated  
N : Non-lube  
H : Air-hydro  
F : Iron tube  
(W/O Magnet)

**4 Bore Size(mm)**  
40 : φ40  
50 : φ50  
63 : φ63  
80 : φ80  
100 : φ100

**5 Stroke/(mm)**  
Bore Size : standard stroke  
40 : 25, 50, 75, 100, 125, 150, 175, 200, 250, 300, 350, 400, 450, 500  
50 : 25, 50, 75, 100, 125, 150, 175, 200, 250, 300, 350, 400, 450, 500, 600  
63 : 25, 50, 75, 100, 125, 150, 175, 200, 250, 300, 350, 400, 450, 500, 600  
80 : 25, 50, 75, 100, 125, 150, 175, 200, 250, 300, 350, 400, 450, 500, 600, 700  
100 : 25, 50, 75, 100, 125, 150, 175, 200, 250, 300, 350, 400, 450, 500, 600, 700

**6 Rod Boot**  
Blank : None  
J : Nylon tarpaulin  
K : Neoprene cloth

**7 Cushion**  
Blank : Both end  
N : None  
H : Head end  
R : Rod end

**8 Special Option**  
Blank : Standard type  
XC16 : Copper-free

**9 Applicable Auto Switch**  
Blank : Without Auto Switch  
W3 : Reed switch type,  
W3(AC100,200V,DC 24V)  
Standard Auto Switch lead wire length is 0.5m.

※ Please suffix L at the end for lead wire of 3m(Optional)  
(Example) W3 - W3L

**10 Number of Switches**  
Blank : 2 pcs.  
S : 1 pc.  
n : n pcs.

#### Model

Model	Type	Action	Seal
AM	Lubricated		O Ring
AMON	Non-lube	Double	Special
AMOH	Air-hydro		Special

## Parts No. Of Mounting Bracket

Bore size	φ 40	φ 50	φ 63	φ 80	φ 100
※ Foot	TCA2L40	TCA2L50	TCA2L63	TCA2L80	TCA2L100
Flange	TCA2F40	TCA2F50	TCA2F63	TCA2F80	TCA2F100
Single clevis	TCA2C40	TCA2C50	TCA2C63	TCA2C80	TCA2C100
Double clevis	TCA2D40	TCA2D50	TCA2D63	TCA2D80	TCA2D100

※ 2 pcs min for order of only one cylinder.

## Specifications

Type	Lube, Non-lube	Air-hydro
Fluid	Air	L.P.Oil
Proof pressure	1.47MPa(213psi)	
Max. operating pressure	0.97MPa(140psi)	
Min. operating pressure	0.05MPa(7psi)	0.1MPa(14psi)
Ambient and fluid temperature	5~60°C(41~140°F)	
Piston speed	50~500mm/s	0.5~300mm/s
Cushion	Air Cushion	Not Available
Stroke tolerance	~250 <sup>st</sup> : <sup>+1.0</sup> / <sub>0</sub> , 251~1,000 <sup>st</sup> : <sup>+1.4</sup> / <sub>0</sub> , 1,001~1,500 <sup>st</sup> : <sup>+1.8</sup> / <sub>0</sub>	
Mounting	Basic, Foot, Front flange, Rear flange, Single clevis, Double clevis, Center trunnion	

## Weight/Aluminum Tube(Iron Tube)

(kgf)

Bore size		φ 40	φ 50	φ 63	φ 80	φ 100
Basic Weight	Basic	0.89 (0.94)	1.36 (1.40)	2.00 (2.04)	3.48 (3.63)	4.87 (5.07)
	Foot	1.08 (1.13)	1.58 (1.62)	2.34 (2.38)	4.15 (4.30)	5.86 (6.06)
	Flange	1.26 (1.30)	1.81 (1.86)	2.79 (2.84)	4.93 (5.08)	6.79 (6.99)
	Single clevis	1.12 (1.17)	1.70 (1.74)	2.63 (2.67)	4.59 (4.74)	6.65 (6.68)
	Double clevis	1.16 (1.21)	1.79 (1.83)	2.79 (2.83)	4.88 (5.03)	7.17 (7.38)
	Trunnion	1.25 (1.35)	1.84 (1.94)	2.80 (3.00)	5.03 (5.32)	7.15 (7.54)
Additional weight per 2" stroke	All mounting bracket (except trunnion iron tube)	0.22 (0.28)	0.28 (0.35)	0.37 (0.43)	0.52 (0.70)	0.65 (0.87)
	Trunnion of iron tube	(0.36)	(0.46)	(0.65)	(0.86)	(1.07)
Accessories	Single knuckle	0.23	0.26	0.26	0.60	0.83
	Double knuckle(with pin)	0.37	0.43	0.43	0.87	1.27

※ In parentheses are for Iron tube type.

### Example

AML 40-100(Foot, φ 40, 100<sup>st</sup>)

- Basic weight ..... 1.08kgf
- Additional weight ..... 0.22/50<sup>st</sup>
- Cylinder stroke ..... 100<sup>st</sup>  
1.08+0.22×100/50=1.52kgf

ACP

UACP

AX

AS

AM2

AM

AL  
ALX

ARD

AQ

AQ2

AJ

AG

AGX  
GX

ADM

ADR

AMR

AST

NLCD

NLCS

NF

NR

ASL

CR/CV

SB

SAH

TPC

W~

# Series AM

## Accessories

Mounting Description		Basic	Foot	Front Flange	Rear Flange	Single Clevis	Double Clevis	Center Trunnion
Standard	Rod End Nut	●	●	●	●	●	●	●
	Clevis Pin	—	—	—	—	—	●	—
Option	Single Knuckle Joint	●	●	●	●	●	●	●
	Double Knuckle Joint(With Pin)	●	●	●	●	●	●	●
	Gaiter	●	●	●	●	●	●	●

## Parts No. Of Auto Switch Mounting Band

Switch Model	Parts No.	Applicable Bore Size(mm)
W3	TBT-04	φ 40
	TBT-04	φ 50
	TBT-06	φ 63
	TBT-08	φ 80
	TBT-08	φ 100

## Base Material And Surface Treatment

Description	Material	Note
Cover	Aluminum Alloy	Silver Paint
Cylinder Tube	Aluminum Alloy	Hard Alumite
	Carbon Steel Tube	Inside/Hard Chrome Plated Outside/Platinum Silver
Seals areal	Lubricated	NBR
	Non-lube	NBR
	Air-hydro	NBR
Piston Rod	Carbon Steel	Hard Chrome Plated
Piston	Aluminum Alloy	Chromate

## Gaiter/Material

Symbol	Material	Max.Ambient Temperature
J	Nylon Tarpaulin	60℃(140°F)
K	Neoprene Cloth	※ 110℃(230°F)

※ For gaiter itself

## Precautions

- ① When mounting, completely flush the piping and be careful that dust and chips do not enter the cylinder.
- ② Load of piston rod should always be aligned parallel with the cylinder axis.
- ③ Avoid damaging (scratches, nicks) on the piston rod, which would lead to damage of rod seal, resulting in air leakage.
- ④ (Lubrication)  
Use non-additive turbine oil ISO-VG32.  
Never use machine oil spindle oil.
- ⑤ (L. P. Oil)  
Use ISO VG-22-46 or equivalent L. P. oil.  
Never use machine oil or spindle oil.
- ⑥ Open air exhaust valve and completely let the inside air out before use.
- ⑦ In case you need cushion only on the air side, you don't have to specify the above. All you have to do is suffix R or H, and for others, follow "How to Order."

## Construction

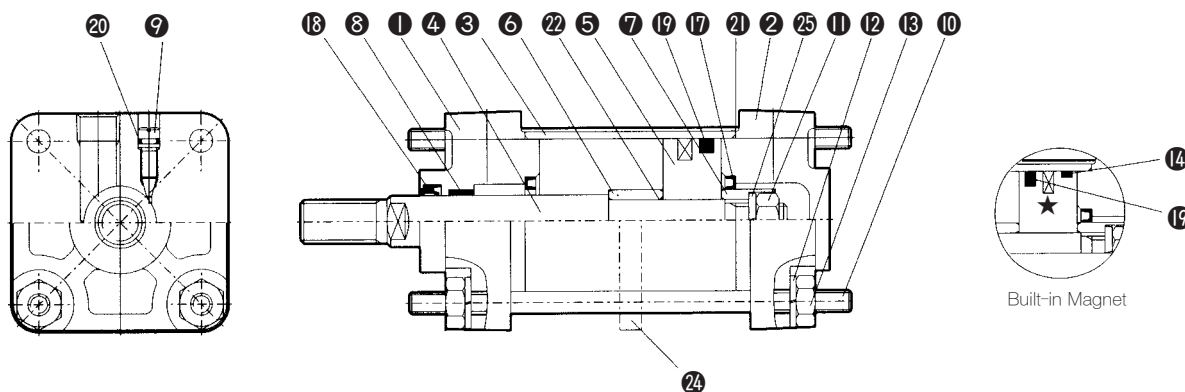

### Parts List

NO.	Description	Material	Note
①	Rod cover	Aluminum alloy	Silver paint
②	Head cover	Aluminum alloy	Silver paint
③	※Cylinder tube	Aluminum alloy	Hard alumite
④	Piston rod	Carbon steel	Hard chrome plated
⑤	Piston	Aluminum alloy	Chromate
⑥	Cushion ring A	Rolled steel	Chromate
⑦	Cushion ring B	Rolled steel	Chromate
⑧	Bush	Lead bronze casting	-
⑨	Cushion Valve	Rolled steel	Chromate
⑩	Tie rod	Carbon steel	Zinc chromate
⑪	Piston nut	Rolled steel	Chromate
⑫	Spring washer	Steel wire	Black Zinc chromate
⑬	Tie rod nut	Rolled steel	Black Zinc chromate
⑭	Wearing	Resin	-
⑳	※Tie rod reinforcing ring	Cast iron	-
㉑	Spring washer	Steel wire	Zinc chromate

※ ㉑ Tie rod reinforcing ring : Available only for 1,000 stroke or more.  
 ※ ③ In the case of Iron tube cylinder : Carbon steel tube, inside hard chrome plated.

### Seals List

NO.	Description	Material	Parts. No.				
			40	50	63	80	100
<b>Lube Type</b>							
⑰	Cushion seal	NBR	DSM-20	DSM-25	DSM-25	DSM-30	DSM-35
⑱	Rod seal		PDU-16Z	PDU-20Z	PDU-20Z	PDU-25Z	PDU-30Z
⑲	Piston seal		P34	P44	P53	P70	P90
㉑	Cushion Valve seal		TC2A040-16A1486		TC2A063-16A1488		
㉒	Cylinder tube gasket		TC2A040-16-1486	TC2A050-16-1487	TC2A063-16-1488	TC2A080-16-1489	TC2A100-16-1490
㉓	Piston gasket		TCA40-1606	TCA63-1608	TCA63-1608	TCA80-1609	TCA100-1610
<b>Lube Type/Long Stroke</b>							
⑲	Piston seal	NBR	NLP-40A	NLP-50A	NLP-63A	NLP-80A	NLP-100A
<b>None-Lube Type</b> Same as lube type except⑱							
⑲	Piston seal	NBR	PSD-40A	PSD-50A	PSD-63A	PSD-80A	PSD-100A
<b>Air-hydro Type</b> Same as lube type except⑱, ⑲ and ㉑							
⑱	Rod seal		SKY-16	SKY-20	SKY-20	SKY-25	SKY-30
⑲	Piston seal	NBR	SDA-40	SDA-50	SDA-63	SDA-80	SDA-100
㉒	Wiper ring		SCB-16	SCB-50	SCB-20	SCB-25	SCB-30

★ Magnet (Built-in Magnet)

ACP

UACP

AX

AS

AM2

AM

AL

ALX

ARD

AQ

AQ2

AJ

AG

AGX

GX

ADM

ADR

AMR

AST

NLCD

NLCS

NF

NR

ASL

CR/CV

SB

SAH

TPC

W~

# Series AM

## Basic Type/(B)

Lube Type(AMB, AMBF), Non-Lube Type(AMBN), Air-Hydro Type(AMBH)

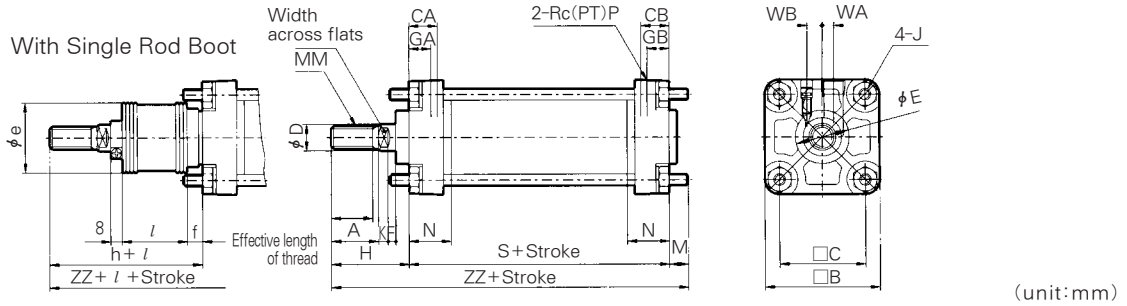

Bore size (mm)	Stroke range(mm)		Effective length of thread	Width across flats	A		CA		CB		φD	φE	F	GA	GB	J	K	M	MM	N	P	S	WA	WB	Without Rod Boot		With Rod Boot		
	Without gaiter	With gaiter			□B	□C	□CA	□CB	H	ZZ															φe	f	h	l	ZZ
φ40	~500	20~500	27	14	30	60	44	18	18	16	32	10	15	15	M8×1.25	6	11	M14×1.5	27	1/4	84	5	10.5	51	146	43	11.2	59	154
φ50	~600	20~600	32	18	35	70	52	21	21	20	40	10	17	17	M8×1.25	7	11	M18×1.5	30	3/8	90	8	9.9	58	159	52	11.2	66	167
φ63	~600	20~600	32	18	35	85	64	21	21	20	40	10	17	17	M10×1.25	7	14	M18×1.5	31	3/8	98	9	11.5	58	170	52	11.2	66	178
φ80	~750	20~750	37	22	40	102	78	26	26	25	52	14	21	21	M12×1.75	11	17	M22×1.5	37	1/2	116	11	13	71	204	65	12.5	80	213
φ100	~750	20~750	37	26	40	116	92	28	28	30	52	14	21	21	M12×1.75	11	17	M26×1.5	40	1/2	126	13	14	72	215	65	14	81	224

## Foot Type/(L)

Lube Type(AML, AMLF), Non-Lube Type(AMLN), Air-Hydro type(AMLH)

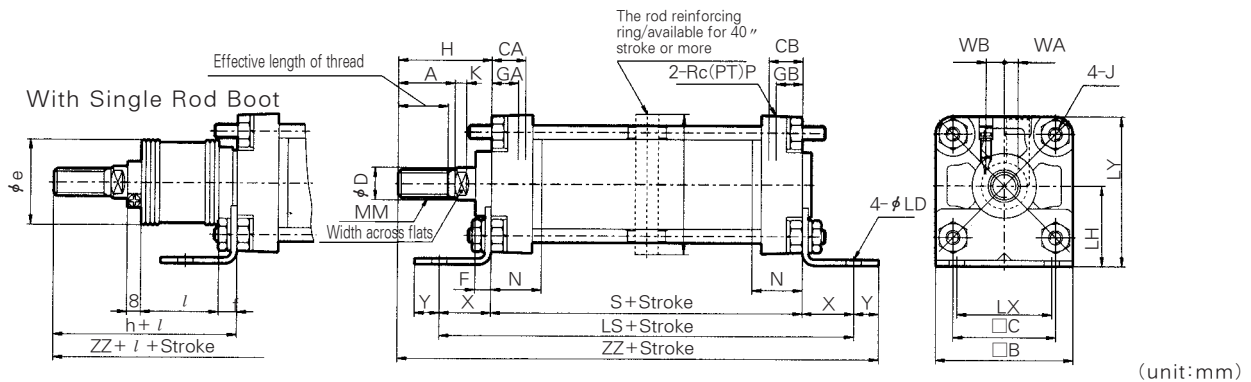

Bore size (mm)	Stroke range(mm)		Effective length of thread	A		CA		CB		φD	φE	F	GA	GB	J	K	MM	N	P	S	WA	WB
	Without Rod Boot	With Rod Boot		□B	□C	□CA	□CB	H	ZZ													
φ40	~500	20~500	27	30	60	44	18	18	16	32	10	15	15	M8×1.25	6	M14×1.5	27	1/4	84	5	10.5	
φ50	~600	20~600	32	35	70	52	21	21	20	40	10	17	17	M8×1.25	7	M18×1.5	30	3/8	90	8	9.9	
φ63	~600	20~600	32	35	85	64	21	21	20	40	10	17	17	M10×1.25	7	M18×1.5	31	3/8	98	9	11.5	
φ80	~750	20~750	37	40	102	78	26	26	25	52	14	21	21	M12×1.75	11	M22×1.5	37	1/2	116	11	13	
φ100	~750	20~750	37	40	116	92	28	28	30	52	14	21	21	M12×1.75	11	M26×1.5	40	1/2	126	13	14	

### Long Stroke Type

Bore size (mm)	X	Y	φLD	LH	LS	LT	LX	LY	Without Rod Boot		With Rod Boot				
									H	ZZ	φe	f	h	l	ZZ
φ40	27	13	9.0	40	138	3.2	42	70	51	175	43	11.2	59	183	
φ50	27	13	9.0	45	144	3.2	50	80	58	188	52	11.2	66	196	
φ63	34	16	11.5	50	166	3.2	59	93	58	206	52	11.2	66	214	
φ80	44	16	13.5	65	204	4.5	76	116	71	247	65	12.5	80	256	
φ100	43	17	13.5	75	212	6.0	92	133	72	258	65	14.0	81	267	

Bore size (mm)	Stroke range (mm)	RT	RY
φ40	501~800	—	—
φ50	601~1200	30	76
φ63	601~1200	40	92
φ80	751~1400	45	112
φ100	751~1500	50	136

Front Flange/(F)

Long Type(AMF, AMFF), Non-Lube Type(AMFN), Air-Hydro Type(AMFH)

With Single Rod Boot

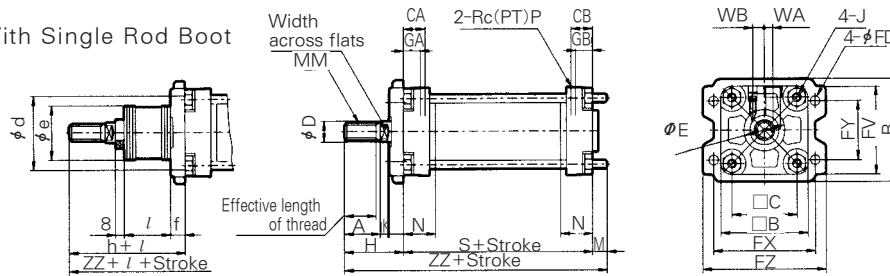

(unit:mm)

Bore size (mm)	Stroke range (mm)		Effective length of thread	A	B	□B	□C	CA	CB	φD	φE	GA	GB	J	K	M	MM	N	P	S	WA	WB
	Without Rod Boot	With Rod Boot																				
φ40	~800	20~800	27	30	71	60	44	18	18	16	32	15	15	M8×1.25	6	11	M14×1.5	27	1/4	84	5	10.5
φ50	~1,000	20~1,000	32	35	81	70	52	21	21	20	40	17	17	M8×1.25	7	11	M18×1.5	30	3/8	90	8	9.9
φ63	~1,000	20~1,000	32	35	101	85	64	21	21	20	40	17	17	M10×1.25	7	14	M18×1.5	31	3/8	98	9	11.5
φ80	~1,000	20~1,000	37	40	119	102	78	26	26	25	52	21	21	M12×1.75	11	17	M22×1.5	37	1/2	116	11	13
φ100	~1,000	20~1,000	37	40	133	116	92	28	28	30	52	21	21	M12×1.75	11	17	M26×1.5	40	1/2	126	13	14

Bore size (mm)	FV	φFD	FT	FX	FY	FZ	Without Rod Boot		With Rod Boot						
							H	ZZ	★φd	φe	f	h	l	ZZ	
φ40	60	9.0	12	80	42	100	51	146	52	43	15	59	1/4 Stroke	154	
φ50	70	9.0	12	90	50	110	58	159	58	52	15	66		167	
φ63	86	11.5	15	105	59	130	58	170	58	52	17.5	66		178	
φ80	102	13.5	18	130	76	160	71	204	80	65	21.5	80		213	
φ100	116	13.5	18	150	92	180	72	215	80	65	21.5	81		224	

★ Hole diameter of Rod Boot to mount Air-cylinder should be larger than the outside diameter of gaiter mounting bracket φd.

Long Stroke(1001 Stroke or more)

With Single Gaiter

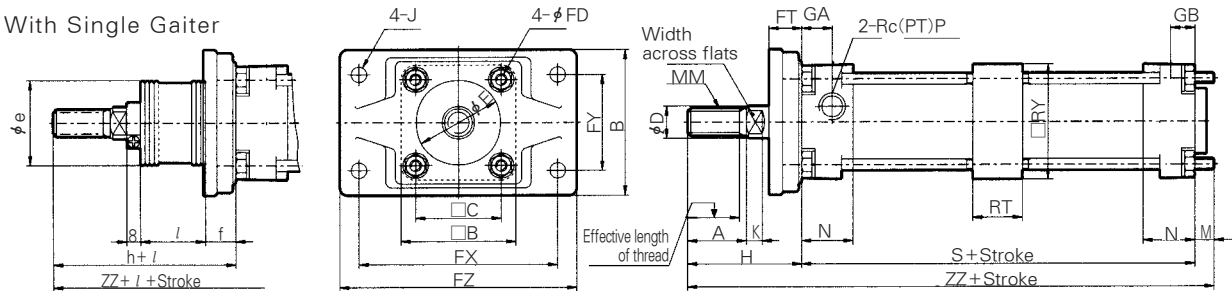

(unit:mm)

Bore size (mm)	Stroke range (mm)	Effective length of thread	A	B	□B	□C	φD	φE	GA	GB	J	K	M	MM	N	P	S	WA	WB
			φ50	1,001~1,200	32	35	88	70	52	20	40	17	17	M8×1.25	7	6	M18×1.5	30	3/8
φ63	1,001~1,200	32	35	105	85	64	20	40	17	17	M10×1.25	7	10	M18×1.5	31	3/8	98	9	11.5
φ80	1,001~1,400	37	40	124	102	78	25	52	21	21	M12×1.75	11	12	M22×1.5	37	1/2	116	11	13
φ100	1,001~1,500	37	40	140	116	92	30	52	21	21	M12×1.75	11	12	M26×1.5	40	1/2	126	13	14

Bore size (mm)	φFD	FT	FX	FY	FZ	RT	RY	Without Rod Boot		With Rod Boot						
								H	ZZ	★φe	f	h	l	ZZ		
φ50	9.0	20	120	58	144	30	76	67	163	52	19	66	1/4 Stroke	162		
φ63	11.5	23	140	64	170	40	92	71	179	52	19	66		174		
φ80	13.5	28	164	84	198	45	112	87	215	65	21	80		208		
φ100	13.5	29	180	100	220	50	136	89	227	65	21	81		219		

★ Hole diameter of rod boot to mount Air-cylinder should be larger than the outside diameter of rod boot mounting bracket φe.

- ACP
- UACP
- AX
- AS
- AM2
- AM
- AL
- ALX
- ARD
- AQ
- AQ2
- AJ
- AG
- AGX
- GX
- ADM
- ADR
- AMR
- AST
- NLCD
- NLCS
- NF
- NR
- ASL
- CR/CV
- SB
- SAH
- TPC
- W~

# Series AM

## Rear Flange/(G)

Lube Type(AMG, AMGF), Non-Lube Type(AMGN), Air-Hydro Type(AMGH)

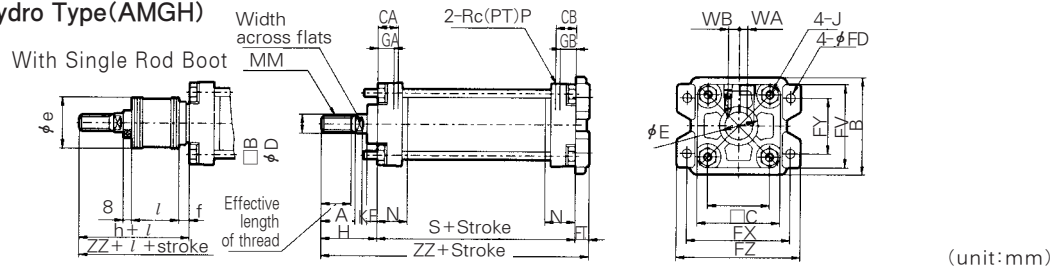

(unit:mm)

Bore size (mm)	Stroke range		Effective length of thread	A	B	□B	□C	CA	CB	φD	φE	F	GA	GB	J	K	MM	N	P	S	WA	WB
	Without Rod Boot	With Rod Boot																				
φ40	~500	20~500	27	30	71	60	44	18	18	16	32	10	15	15	M8×1.25	6	M14×1.5	27	1/4	84	5	10.5
φ50	~600	20~600	32	35	81	70	52	21	21	20	40	10	17	17	M8×1.25	7	M18×1.5	30	3/8	90	8	9.9
φ63	~600	20~600	32	35	101	85	64	21	21	20	40	10	17	17	M10×1.25	7	M18×1.5	31	3/8	98	9	11.5
φ80	~750	20~750	37	40	119	102	78	26	26	25	52	14	21	21	M12×1.75	11	M22×1.5	37	1/2	116	11	13
φ100	~750	20~750	37	40	133	116	92	28	28	30	52	14	21	21	M12×1.75	11	M26×1.5	40	1/2	126	13	14

Bore size (mm)	FV	φFD	FT	FX	FY	FZ	Without Rod Boot		With Rod Boot				
							H	ZZ	φe	f	h	l	ZZ
φ40	60	9.0	12	80	42	100	51	147	43	11.2	59	1/4 Stroke	155
φ50	70	9.0	12	90	50	110	58	160	52	11.2	66		168
φ63	86	11.5	15	105	59	130	58	171	52	11.2	66		179
φ80	102	13.5	18	130	76	160	71	205	65	12.5	80		214
φ100	116	13.5	18	150	92	180	72	216	65	14.0	81		225

## Single Clevis/(C)

Lube Type(AMC, AMCF), Non-Lube Type(AMCN), Air-Hydro Type(AMCH)

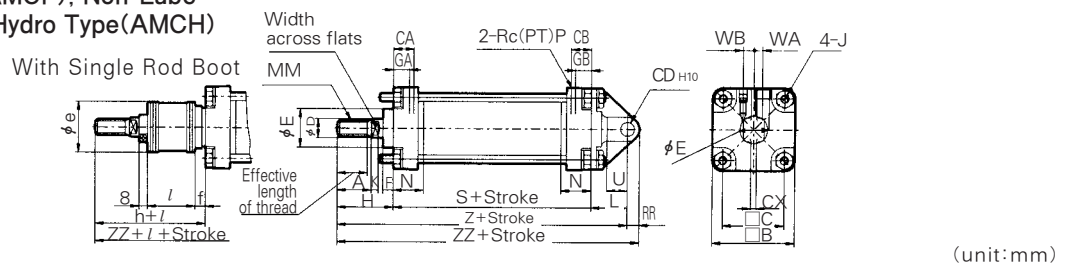

(unit:mm)

Bore size (mm)	Stroke range		Effective length of thread	A	□B	□C	CA	CB	φD	φE	F	GA	GB	J	K	L	MM	N	P	S	WA	WB
	Without Rod Boot	With Rod Boot																				
φ40	~500	20~500	27	30	60	44	18	18	16	32	10	15	15	M8×1.25	6	30	M14×1.5	27	1/4	84	5	10.5
φ50	~600	20~600	32	35	70	52	21	21	20	40	10	17	17	M8×1.25	7	35	M18×1.5	30	3/8	90	8	9.9
φ63	~600	20~600	32	35	85	64	21	21	20	40	10	17	17	M10×1.25	7	40	M18×1.5	31	3/8	98	9	11.5
φ80	~750	20~750	37	40	102	78	26	26	25	52	14	21	21	M12×1.75	11	48	M22×1.5	37	1/2	116	11	13
φ100	~750	20~750	37	40	116	92	28	28	30	52	14	21	21	M12×1.75	11	58	M26×1.5	40	1/2	126	13	14

Bore size (mm)	RR	U	φCD <sub>H10</sub>	CX	Without Rod Boot		With Rod Boot						
					H	Z	ZZ	φe	f	h	l	Z	ZZ
φ40	10	16	10	15.0 <sup>+0.058</sup> <sub>0</sub>	51	165	175	43	11.2	59	1/4 Stroke	173	183
φ50	12	19	12	18.0 <sup>+0.070</sup> <sub>0</sub>	58	183	195	52	11.2	66		191	203
φ63	16	23	16	25.0 <sup>+0.070</sup> <sub>0</sub>	58	196	212	52	11.2	66		204	220
φ80	20	28	20	31.5 <sup>+0.084</sup> <sub>0</sub>	71	235	255	65	12.5	80		244	264
φ100	25	36	25	35.5 <sup>+0.084</sup> <sub>0</sub>	72	256	281	65	14.0	81		265	290

Double Clevis Type/(D)

Lube type(AMD, AMDF), Non-Lube Type(AMDN), Air-Hydro Type(AMDH)

With Single Rod Boot

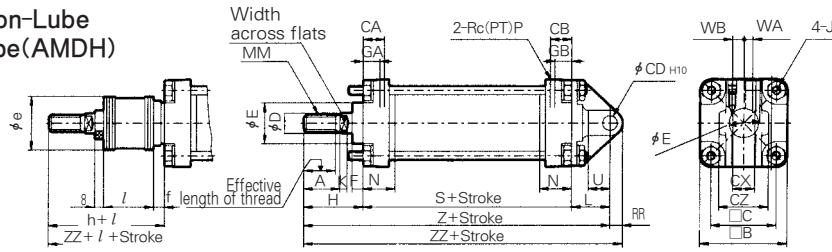

(unit:mm)

Bore size (mm)	Stroke range		Effective length of thread	A	□B	□C	CA	CB	φD	φE	F	GA	GB	J	K	L	MM	N	P	S	WA	WB
	Without Rod Boot	With Rod Boot																				
φ40	~500	20~500	27	30	60	44	18	18	16	32	10	15	15	M8×1.25	6	30	M14×1.5	27	1/4	84	5	10.5
φ50	~600	20~600	32	35	70	52	21	21	20	40	10	17	17	M8×1.25	7	35	M18×1.5	30	3/8	90	8	9.9
φ63	~600	20~600	32	35	85	64	21	21	20	40	10	17	17	M10×1.25	7	40	M18×1.5	31	3/8	98	9	11.5
φ80	~750	20~750	37	40	102	78	26	26	25	52	14	21	21	M12×1.75	11	48	M22×1.5	37	1/2	116	11	13
φ100	~750	20~750	37	40	116	92	28	28	30	52	14	21	21	M12×1.75	11	58	M26×1.5	40	1/2	126	13	14

Bore size (mm)	RR	U	φCD <sub>H10</sub>	CX	CZ	Without Rod Boot			With Rod Boot					
						H	Z	ZZ	φe	f	h	l	Z	ZZ
φ40	10	16	10	15.0	29.5	51	165	175	43	11.2	59	1/4 Stroke	173	183
φ50	12	19	12	18.0	38	58	183	195	52	11.2	66		191	203
φ63	16	23	16	25.0	49	58	196	212	52	11.2	66		204	220
φ80	20	28	20	31.5	61	71	235	255	65	12.5	80		244	264
φ100	25	36	25	35.5	64	72	256	281	65	14.0	81		265	290

Center Trunnion Type/(T)

Lube Type(AMT, AMTF), Non-lube Type(AMTN), Air-hydro type(AMTH)

With Single Rod Boot

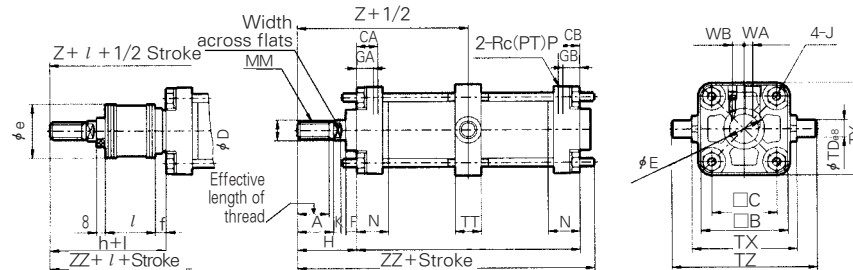

(unit:mm)

Bore size (mm)	Stroke range		Effective length of thread	A	□B	□C	CA	CB	φD	φE	F	GA	GB	J	K	MM	N	P	S	WA	WB
	Without Rod Boot	With Rod Boot																			
φ40	~500	20~500	27	30	60	44	18	18	16	32	10	15	15	M8×1.25	6	M14×1.5	27	1/4	84	5	10.5
φ50	~600	20~600	32	35	70	52	21	21	20	40	10	17	17	M8×1.25	7	M18×1.5	30	3/8	90	8	9.9
φ63	~600	20~600	32	35	85	64	21	21	20	40	10	17	17	M10×1.25	7	M18×1.5	31	3/8	98	9	11.5
φ80	~750	20~750	37	40	102	78	26	26	25	52	14	21	21	M12×1.75	11	M22×1.5	37	1/2	116	11	13
φ100	~750	20~750	37	40	116	92	28	28	30	52	14	21	21	M12×1.75	11	M26×1.5	40	1/2	126	13	14

Bore size (mm)	φTD <sub>e8</sub>	TT	TX	TY	TZ	Without Rod Boot			With Rod Boot					
						H	Z	ZZ	φe	f	h	l	Z	ZZ
φ40	15	22	85	62	117	51	93	140	43	11.2	59	1/4 Stroke	101	148
φ50	15	22	95	74	127	58	103	154	52	11.2	66		111	162
φ63	18	28	110	90	148	58	107	162	52	11.2	66		115	170
φ80	25	34	140	110	192	71	129	194	65	12.5	80		138	203
φ100	25	40	162	130	214	72	135	206	65	14.0	81		144	215

- ACP
- UACP
- AX
- AS
- AM2
- AM
- AL  
ALX
- ARD
- AQ
- AQ2
- AJ
- AG
- AGX  
GX
- ADM
- ADR
- AMR
- AST
- NLCD
- NLCS
- NF
- NR
- ASL
- CR/CV
- SB
- SAH
- TPC
- W~



# Series AM

## Rod End Nut(Standard accessories) (mm)

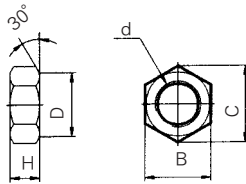

Material : Rolled steel

Part No.	Applicable bore	d	H	B	C	D
TNT-04	φ 40	M14×1.5	8	22	25.4	21
TNT-05	φ 50 · φ 63	M18×1.5	11	27	31.2	26
TNT-08	φ 80	M22×1.5	13	32	37.0	31
TNT-10	φ 100	M26×1.5	16	41	47.3	39

## Knuckle Joint Pin/Clevis Pin (mm)

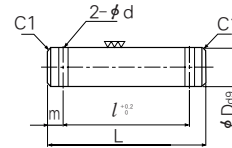

Material : Carbon steel

Part No	Bore Size		φ Dd9	L	l	m	φ d	Applicable split pin φ × l
	CLEVIS	KNUCKLE						
TCDP-2	φ 40	—	10 <sup>-0.040/-0.076</sup>	45.2	37.2	4	φ 3	φ 3×18l
TCDP-3	φ 50	φ 40 · φ 63	12 <sup>-0.050/-0.093</sup>	54.3	46.3	4	φ 3	φ 3×18l
TCDP-4	φ 63	—	16 <sup>-0.050/-0.093</sup>	70	60	5	φ 4	φ 4×24l
TCDP-5	—	φ 80	18 <sup>-0.040/-0.076</sup>	76	66	5	φ 4	φ 4×25l
TCDP-6	φ 80	φ 100	20 <sup>-0.065/-0.117</sup>	82	72	5	φ 4	φ 4×36l
TCDP-7	φ 100	—	25 <sup>-0.065/-0.117</sup>	87.5	77.5	5	φ 4	φ 4×36l

## I Type Single Knuckle Joint (mm)

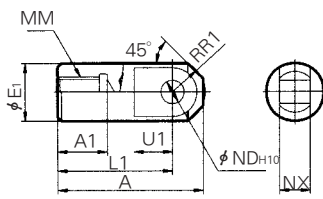

Material : Free cutting sulfur steel

Part No.	Applicable bore	A	A1	φ E1	L1	MM	R1	U1	φ ND <sub>H10</sub>	NX
TI-04	φ 40	69	22	24	55	M14×1.5	15.5	20	12 <sup>-0.070/-0</sup>	16 <sup>-0.1/-0.3</sup>
TI-05	φ 50 · φ 63	74	27	28	60	M18×1.5	15.5	20	12 <sup>-0.070/-0</sup>	16 <sup>-0.1/-0.3</sup>
TI-08	φ 80	91	37	36	71	M22×1.5	22.5	26	18 <sup>-0.070/-0</sup>	28 <sup>-0.1/-0.3</sup>
TI-10	φ 100	105	37	40	83	M26×1.5	24.5	28	20 <sup>-0.084/-0</sup>	30 <sup>-0.1/-0.3</sup>

## Y Type Double Knuckle Joint (mm)

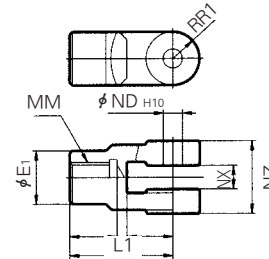

Cast iron

Part No.	Applicable bore	A1	φ E1	L1	MM	R1	U1	φ ND <sub>H10</sub>	NX	NZ
TY-04A	φ 40	22	24	55	M14×1.5	13	25	12 <sup>+0.070/+0</sup>	16 <sup>+0.3/+0.1</sup>	38
TY-05A	φ 50 · φ 63	27	28	60	M18×1.5	15	27	12 <sup>+0.070/+0</sup>	16 <sup>+0.3/+0.1</sup>	38
TY-08A	φ 80	37	36	71	M22×1.5	19	28	18 <sup>+0.070/+0</sup>	28 <sup>+0.3/+0.1</sup>	55
TY-10A	φ 100	37	40	83	M26×1.5	21	38	20 <sup>+0.084/+0</sup>	30 <sup>+0.3/+0.1</sup>	61

## Trunnion Bracket

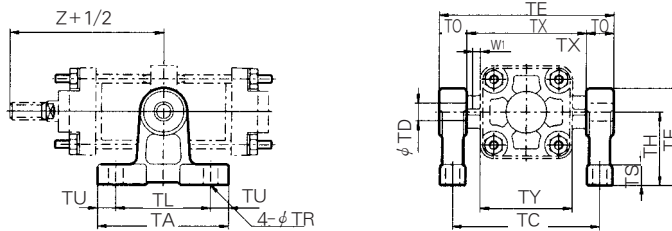

(mm)

Part No.	Applicable bore	TA	TL	TU	TC	TX	TE	TO	φ TR	φ TT	TS	TH	TF	TY	W1	Z	φ TD-H10
TCA1-S04	φ 40	80	60	10	102	85	119	17	9	17	12	45	60	62	10	93	15 <sup>+0.070/0</sup>
	φ 50	80	60	10	112	95	129	17	9	17	12	45	60	74	10	103	15 <sup>+0.070/0</sup>
TCA1-S06	φ 63	100	70	15	130	110	150	20	11	22	14	55	73	90	10	107	18 <sup>+0.070/0</sup>
TCA1-S08	φ 80	120	90	15	166	140	192	26	13.5	24	17	75	100	110	12	129	25 <sup>+0.084/0</sup>
	φ 100	120	90	15	188	162	214	26	13.5	24	17	75	100	130	12	135	25 <sup>+0.084/0</sup>